

Upgrading Study of Kuwait High Voltage Network 275 KV

Ali Yusuf Al-Eidy

The public authority for applied education and training (PAAET)

Kuwait

ABSTRACT

Kuwait transmission network (275 kV network) has a significant increase in short circuit level at some grid and power stations substations above the system limitations (80 % of the rupture capacity of the system 63 kA). This increase results from the growth of power demand and the increase of transmission network complexity. New power stations will be added in the next few years. This paper describes a solution to the problem by splitting the transmission network into three zones as well as constructing new high voltage transmission network (i.e. 400 kV) and connects it with the existing 275 kV network. All the new power stations must be connected to the new 400 kV network and the connection to the 275 kV network must be stopped.

Keywords: High Voltage transmission, Network Splitting, Short circuit level (SCL), Transmission network.

I. INTRODUCTION

The problem in Kuwait started at 2005 when a new emergency generation units were added to the network as a quick measure to avoid load shedding during heavy-load summer season. With the long term plan, new large generating stations are also expected to be installed. As a result, the short circuit level has increased and it is expected to highly increase in the near future [1].

Some solutions were applied to reduce the short circuit level like dividing substations bus bars, but it was with limited results in some substations and non-applicable in others. Many other solutions like:

1. Changing lines from AC to DC.
2. Applying Fault Current Limiters.
3. Upgrading the system Voltage.

The above mentioned solutions were not applied because of there high expenses. Instead this paper presents an applicable, reliable solution for the SCL problem by splitting the 275 kV network and constructing new transmission network (i.e. 400 kV) at the same time to reduce the SCL in the grid and power stations substations. Network splitting process is very complicated when applied to large and complicated networks, which is not the case for Kuwait network. First we have to find the splitting strategy that corresponds to an acceptable steady state operation of the whole system after splitting so that the system avoids collapse or cascade blackout [2]. The splitting strategy is the most difficult process in splitting networks so that the best splitting points must be selected. Also load/generations balance must be satisfied for each zone or area after splitting as well as satisfaction of transmission system parts capacity constraints (lines, bus bars, switchgears)

II. EXISTING 275 kV NETWORK & ITS SCL

Kuwait 275 kV network consists of three power stations (Sabbia SBPS, Doha west DWPS, and Zour south), and 24 grid substations that are connected with overhead lines and underground cable. Table 1 shows the network (grid & power stations) substations [3].

Table 1: 275 kV network substations

No	Power stations substations	Grid substations
1	DWPS	AHMD W
2	SBPS	ARDY W
3	ZSPS	FINT W
4		JBAH W
5		FRRD W
6		JABR W
7		JAHR W
8		OMAR W
9		SLAM W
10		SLAM X
11		SHKH W
12		SHUB W
13		SHUB X
14		SLBY W
15		SRRD W
16		QURN W
17		SSSM W
18		SSUR W
19		TOWN W
20		WJLB W
21		OL2K W
22		JAHR W
23		KIFN W
24		GBTL W

Table 2: SCL at 2008 & 2009

NAME	2008 % of Rup Cap	2009 % of Rup Cap
ARDY W	81%	85%
FINT W	85%	91%
FRRD W	87%	92%
JABR W	87%	92%
OMRA W	88%	89%
SALM W	84%	90%
SHKH W	86%	94%
SRRD W	92%	85%
SSSM W	85%	84%
SSUR W	89%	93%
TOWN W	84%	88%

Figure 1 shows Kuwait 275 kV transmission network. Only three power stations are connected to 275 kV network and the rest power stations connected to the 132 kV network .The national control center (NCC) in the ministry of electricity and water (MEW) reports stated that the short circuit level starts to increase above the electrical limits (80% of the switchgear rupture capacity) at 2005. Tables 2 & 3 shows the SCL at some substations [4].

III. THEORETICAL BACKGROUND

- **Bus Impedance matrix (Z_{bus})**

The network impedance at any bus is given by:

$$Z_{bus} = \begin{bmatrix} Z_{11} & Z_{12} & \dots & Z_{1N} \\ Z_{21} & Z_{22} & \dots & Z_{2N} \\ \dots & \dots & \dots & \dots \\ Z_{N1} & Z_{N2} & \dots & Z_{NN} \end{bmatrix}$$

- **Short circuit current (I_{sc})**

The instantaneous short circuit current ($i_{sc}(t)$) for a power system where the impedance is due to mainly to transmission lines and transformers is inductive [4][5], is given by:

$$i_{sc}(t) = \underbrace{\frac{V}{|Z|} \sin(\omega t + \alpha - \theta)}_{\text{Symmetrical short circuit current}} + \underbrace{\frac{V}{|Z|} \sin(\theta - \alpha) e^{-\left(\frac{R}{L}\right)t}}_{\text{D.C. off-set current}} \quad (1)$$

If the fault occurs at bus K, the short circuit current (I_{sc}) or the fault current (I_{sc}) at bus K can be given by:

$$|I_{sc,K}| = \frac{V_K(0)}{Z_{KK} + Z_{sc}}$$

Where $V_K(0)$ is the prefault voltage of bus K, Z_{sc} is the impedance of the fault, Z_{KK} is the Thevenin's equivalent impedance of the network at bus K.

- **Short circuit MVA**

The short circuit MVA for the network could be given by:

$$MVA_{sc} = \sqrt{3} I_{sc} V_l$$

Where I_{sc} is the fault or short circuit current in (kA), V_l is the nominal line voltage in (kV).

Where Z is the network impedance ($R+jX$) at fault location [5].

IV. CALCULATING Z BEFORE SPLITTING

Equation (1) indicates that the network impedance at fault has significant effect on the short current level, so by controlling (Z), I_{sc} could be controlled. The impedance Z for the must be calculated before and after splitting the network. The per unit calculations method will be used to calculate the fault impedance (Z) at the same points (substations) before and after splitting. The selected substations will be SLPY W, JABR W, and FINT W. The 275 kV network power stations have deferent installed capacity and using open cycled steam & gas turbines as well as using 375 MVA transformers to step up the voltage from 21 to 275 kV [6].

$$\begin{aligned}
 MVA_{base} &= 400 \text{ MVA} && \text{(for the system)} \\
 V_{base,gen} &= 21 \text{ kV} && \text{(for the generation)} \\
 V_{base,TL} &= 275 \text{ kV} && \text{(for the Transmission lines)} \\
 \text{Power Factor (PF)} &= 0.85 && \text{(for the system)} \\
 MVA_{rated,gen} &= 352.94 \text{ MVA} && \text{(for single generator)} \\
 MVA_{rated,tr} &= 375 \text{ MVA} && \text{(for single transformer)} \\
 Z_{gen} &= 15\% && \text{(for single generator)} \\
 Z_{tr} &= 13.79\% && \text{(for single transformer)} \\
 Z_{turb} &= Z_{gen} + Z_{tr} && \text{(for single turbine)} \\
 Z_{pu,gen} &= j0.17 \text{ p.u} \\
 Z_{pu,tr} &= j0.18396 \text{ p.u} \\
 Z_{turb} &= j0.31709 \text{ p.u} \\
 Z_{SBPS} &= j0.022649 \text{ p.u} \\
 Z_{ZSPS} &= j0.019818 \text{ p.u} \\
 Z_{DWPS} &= j0.028826 \text{ p.u}
 \end{aligned}$$

1. Fault at SLPY W

In the case of 3Ø fault at SLPY W substations the resulted fault impedance Z_f for the network will be:

$$\begin{aligned}
 Z_{SLPY,f} &= 0.001385 + j0.030439 \text{ p.u} \\
 X/R &= 22
 \end{aligned}$$

2. Fault at JABR W

In the case of 3Ø fault at JABR W substations the resulted fault impedance Z_f for the network will be:

$$\begin{aligned}
 Z_{SLPY,f} &= 0.00115 + j0.029095 \text{ p.u} \\
 X/R &= 25
 \end{aligned}$$

3. Fault at FINT W

In the case of 3Ø fault at FINT W substations the resulted fault impedance Z_f for the network will be:

$$\begin{aligned}
 Z_{FINT,f} &= 0.001137 + j0.026060 \text{ p.u} \\
 X/R &= 23
 \end{aligned}$$

V. NETWORK SPLITTING

Splitting transmission network must ensure the best selection to the splitting points at the grid substations that ensures the following criteria's for the whole system:

- Generation/load balance.
- Satisfaction of the transmission network system equipment’s capacity constraints.
- Acceptable steady state operation & transient circumstances of the system.
- Economical & real implementation echo's.

Table 3 shows the splitting points that can be used to split the 275 kV network in to three parts, Northern, Central, and southern. From Fig. 1 it can be seen that the selected splitting points are the best with regard to technical and economical point views, because there is no need for the construction of new transmission lines to connect the three parts of the new network scheme to supply energy in the case of emergency. Also the Selected splitting points insure good security for network stability in the case of emergency because each line has more than one feeder. The new network is in Fig 5.

Table 3: Splitting points

Line #	From	to	# of feeders
1	DWPS S/S	WJLB W	2
2	SSRD W	SSUR W	2
3	Jahr X	AHMD W	2
4	SLBY W	FINT W	2

Table 4 shows the three sub-networks (parts) with regard to peak load and generation at 2010.

Table 4: 275 kV network after splitting with 2010 peak load & maximum generation

Area name	Power stations	Substations	load	Generation
Northern (Red area)	SBPS	Jahr X Jahr W WJLB W JBAH W SLBY W	1222	3929
Central (Blue area)	DEPS SHKG DWPS	SHKH W TOWN W ARDY W JABR X SDIQ W OMAR W FRRD W SSUR W	2763	3600
Southern (Green area)	ZSPS SSPS	SALM X SALM W JABR W	4513	5145

		QURN W		
		SRRD W		
		FINT W		
		SSSM W		
		AHMD W		
		SHUB X		
		SHUB W		
		OL2K W		

VI. CALCULATING Z AFTER SPLITTING

The same procedure applied in V will be applied to the new network after splitting (i.e. Fig. 5) to find the impedance Z for the same substations (SLPY W, JABR W, and FINT W).

1. Fault at SLPY W

$$Z_{SLPY,f} = Br_2 + Z_{ZSPS} = 0.0054018 + j0.10241 \text{ p.u}$$

$$X/R = 19$$

2. Fault at JABR W

$$Z_{JABR,f} = Br_5 + Br_{28} + Z_{DWPS} = 0.001435 + j0.050788 \text{ p.u}$$

$$X/R = 35$$

3. Fault at FINT W

$$Z_{FINT,f} = Br_{18} + Br_{34} + Br_{36} + Z_{ZSPS} = 0.003124 + j0.067588 \text{ p.u}$$

$$X/R = 21$$

VII. COMPARISON OF FAULT IMPEDANCES BEFORE & AFTER SPLITTING

It can be noted that the fault impedance (Z_f) for all the case studied increased as in the following:

1. SLPY W substation

The short circuit impedances before and after network splitting are:

Table 5: SLPY W fault impedance (Z_f) comparison

	<i>Before split</i>	<i>After split</i>
Z_f	$0.001385 + j0.030439$ <i>p.u</i>	$0.0054018 + j0.10241$ <i>p.u</i>
X/R	X/R = 22	X/R = 19

2. FINT W substation

The short circuit impedances before and after network splitting are:

Table 6: FINT W fault impedance (Z_f) comparison

	<i>Before split</i>	<i>After split</i>
Z_f	$0.001137+j0.026060$ <i>p.u</i>	$0.003124+j0.067588$ <i>p.u</i>
X/R	$X/R = 23$	$X/R=21$

3. JABR W substation

The short circuit impedances before and after network splitting are:

Table 7: JABR W fault impedance (Z_f) comparison

	<i>Before split</i>	<i>After split</i>
Z_f	$0.00115+j0.029095$ <i>p.u</i>	$0.001435+j0.050788$ <i>p.u</i>
X/R	$X/R = 23$	$X/R=35$

From tables 5 , 6, and 7 it can be seen that the impedance will increase which will result a reduction in the short circuit current (SC).

VIII. NEW TRANSMISSION NETWORK VOLTAGE LEVEL

The new voltage level network, i.e. the 400 kV must be homogenous and support the 275 kV network after splitting to insure the best performance and security, so it is recommended to start the 400 kV network with three substations as in Fig. 9.

IX. SIMULATION RESULTS

By using MATLAB software the SCL currents & voltage waveforms are gotten to check that if the proposed approach for solving the high SCL is useful or not:

- Simulation before splitting at a fault at JABR W substation:
Figures 4,5,6,7,8,9,10 shows the SCC and voltage waveforms.
- Simulation before splitting at a fault at FNTS W substation:
Figures 11,12,13,14,15, and 16 shows the SCC and voltage waveforms.
- Simulation after splitting at a fault at JABR W substation:
Figures 17 & 18 shows the SCC and voltage waveforms.
- Simulation after splitting at a fault at FNTS W substation:
Figures 19 & 20 shows the SCC and voltage waveforms.

X.CONCLUSIONS

The 275 kV transmission network faces a major problem that may damage the network equipment's in the case of fault because of the high short circuit levels (SCL) which exceeds the network safety standards (80 % from the rupture capacity of the switch gears) of the network, and this is because of the following:

- Adding new power stations as well as adding new generating units to the network to supply the increase of load demand.
- The short distances between the power stations and substations which results low impedance for the whole network.

XI. RECOMMENDATIONS

1) Constructing new transmission network with voltage level of 400 kV, and the new network is the back bone network of the whole system that starts with 3 substations and then expanded with strategic plane of the country depending on the energy annual growth. Also all the new power stations or any new generation units must be connected to the 400 kV network and the connection to the 275 kV network must be stopped.

2) The 275 kV network must be splitted in to 3 zones each with its own generation, and the 3 zones connected at some points (transmission lines normally opened) that can be used in the case of emergency.

REFERENCES

[1] Mahmud Gilany, Wael Al-Hasawi, "Reducing the Short Circuit Levels in Kuwait Transmission Network (A Case Study)", World Academy of Science, Engineering and Technology 53 2009, PP. 592-596

[2] Qianchuan Zhao, Kai Sun, Da-Zhong Zhang, Jin Ma, Qiang Lu, Fellow, "A Study of System Splitting Strategies for Island Operation of Power System: A Two-Phase Method Based on OBDDs", IEEE TRANSACTIONS ON POWER SYSTEMS, VOL. 18, NO. 4, November 2003, PP. 1556-1565

[3] Statistical Year Book, Ministry of Electricity and Water (MEW), Kuwait, 2011

[4] National Control Center (NCC) Annual Report.

[5] Dr. S. Sivanagaraju, B.V. Rami Reddy, "Electrical Power System Analysis Book, 2007

[6] D P Kothari, I J Nagrath, Modern Power Syatem Analysis Book, 2005

Appendix

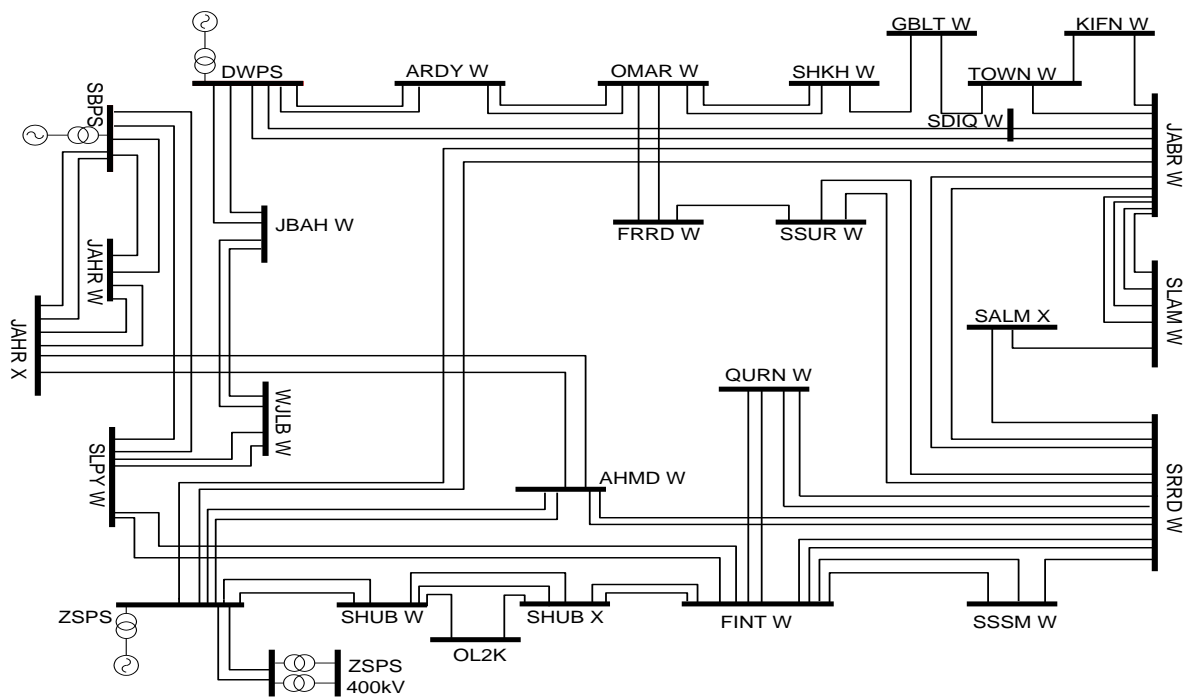

Fig. 1 The 275 kV Kuwait transmission network

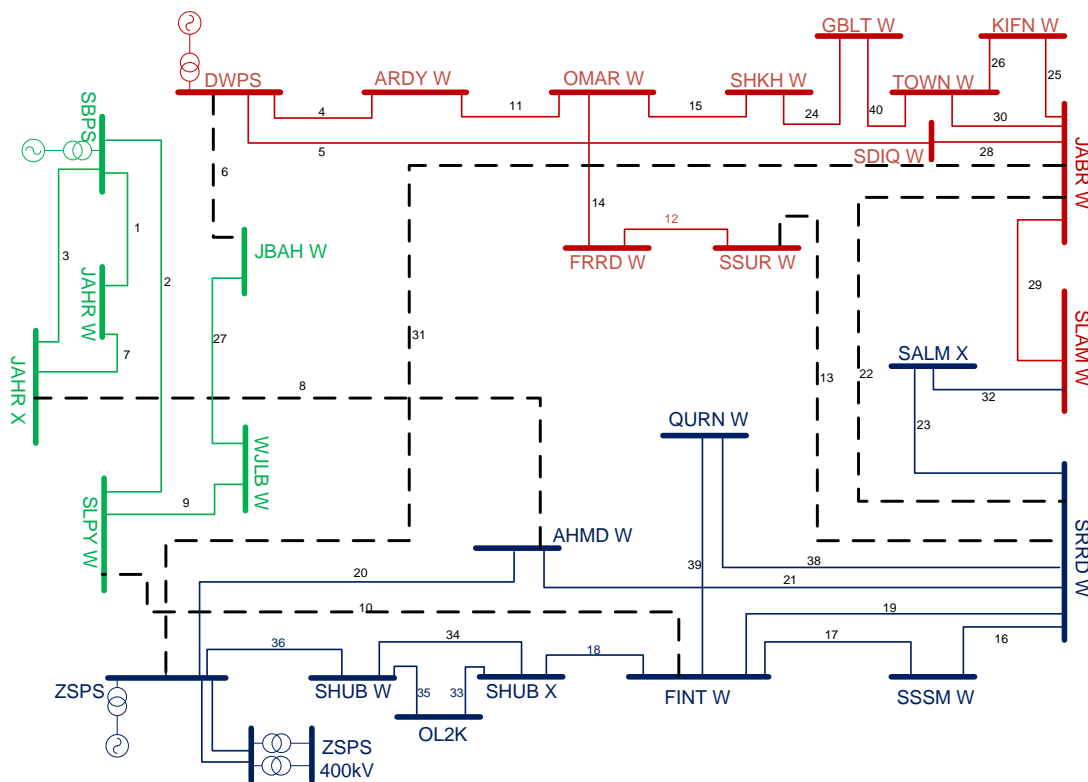

Fig 2 The 275 kV network after splitting into three zones

* The dashed lines are the splitting points (feeders that will be normally open).

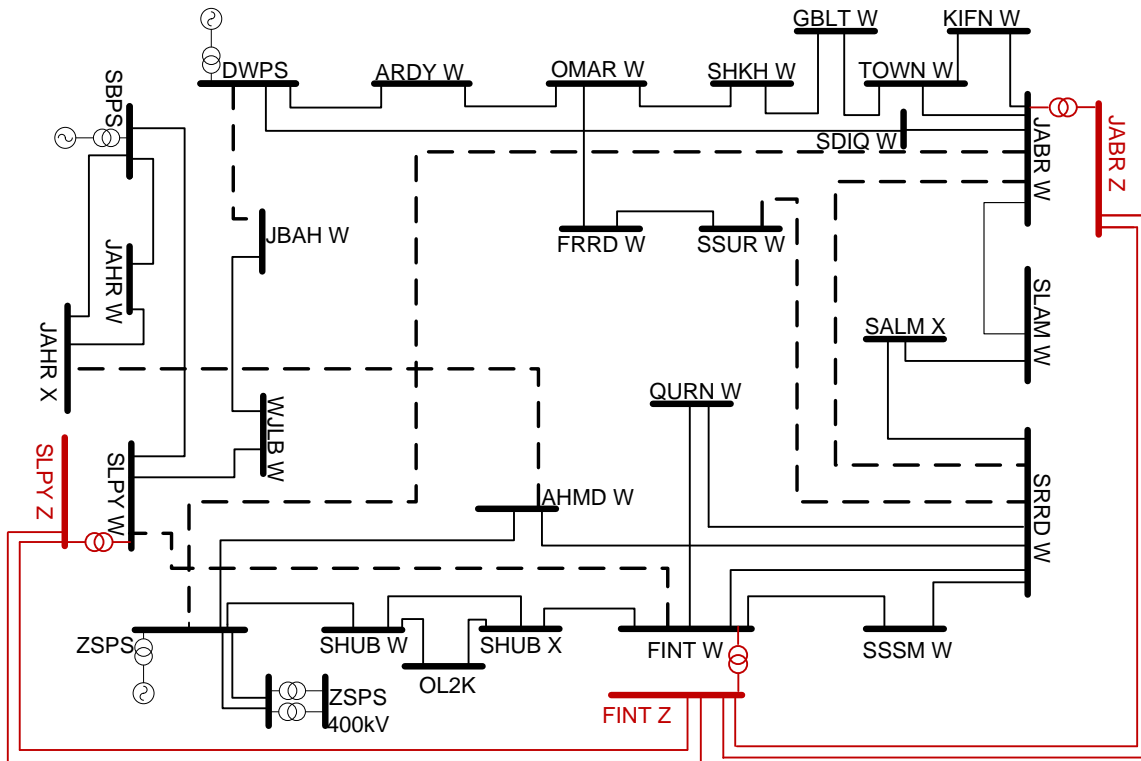

Fig. 3 The proposed 400 & 275 kV network after splitting

* 400 kV network in red

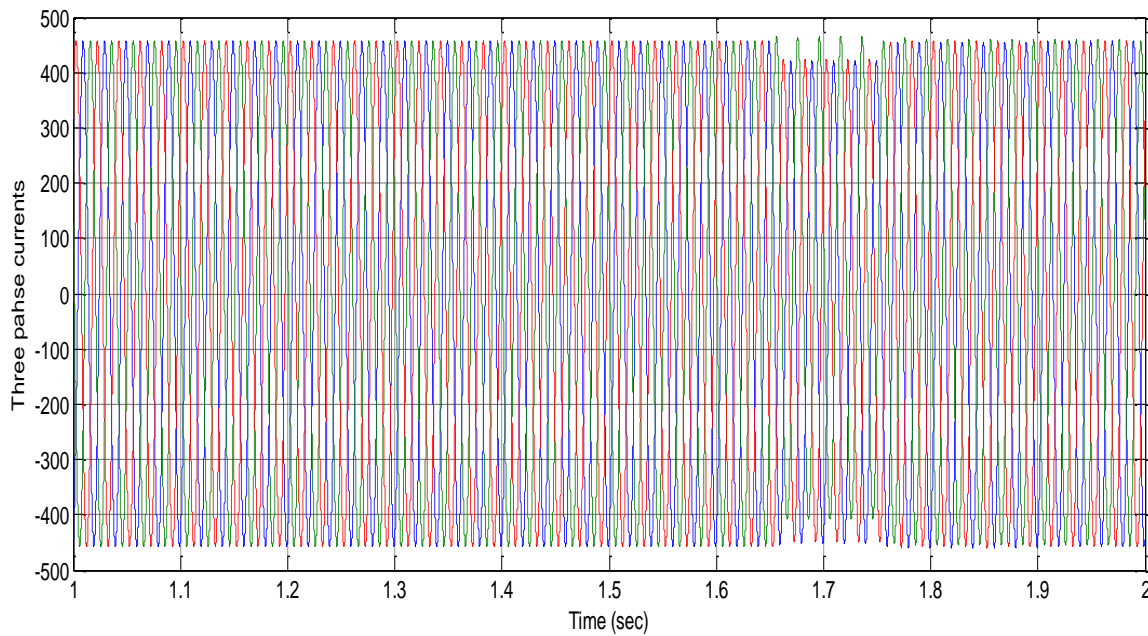

Figure 5 The current at SLPY W

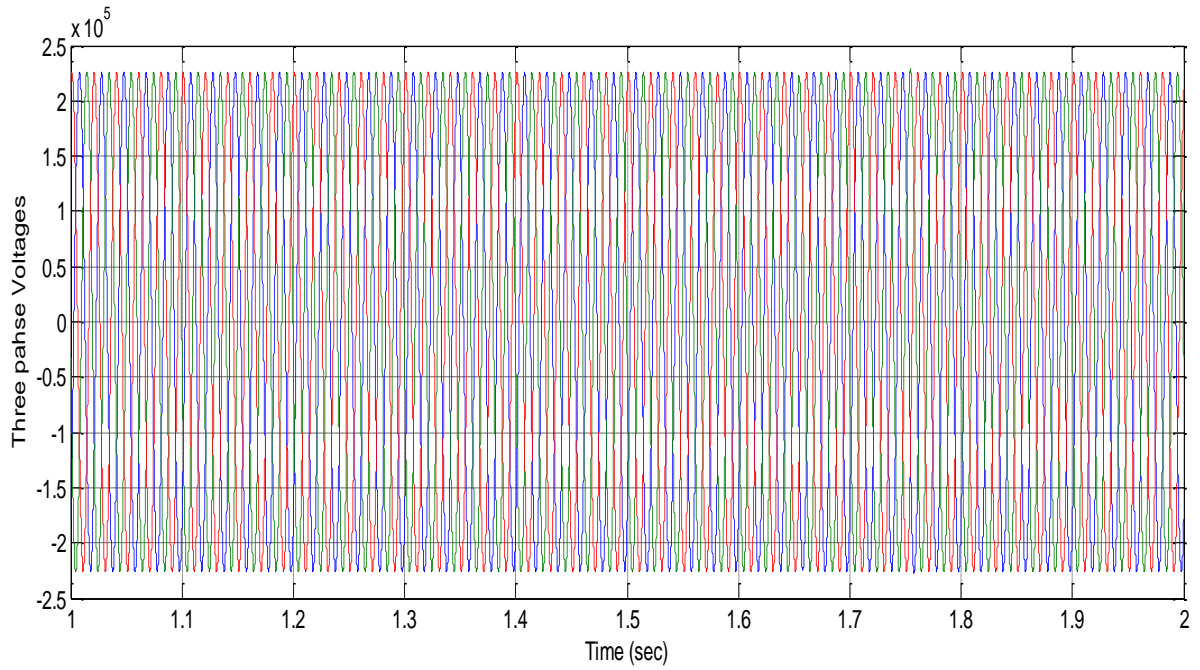

Figure 6 The voltage at SLPY W

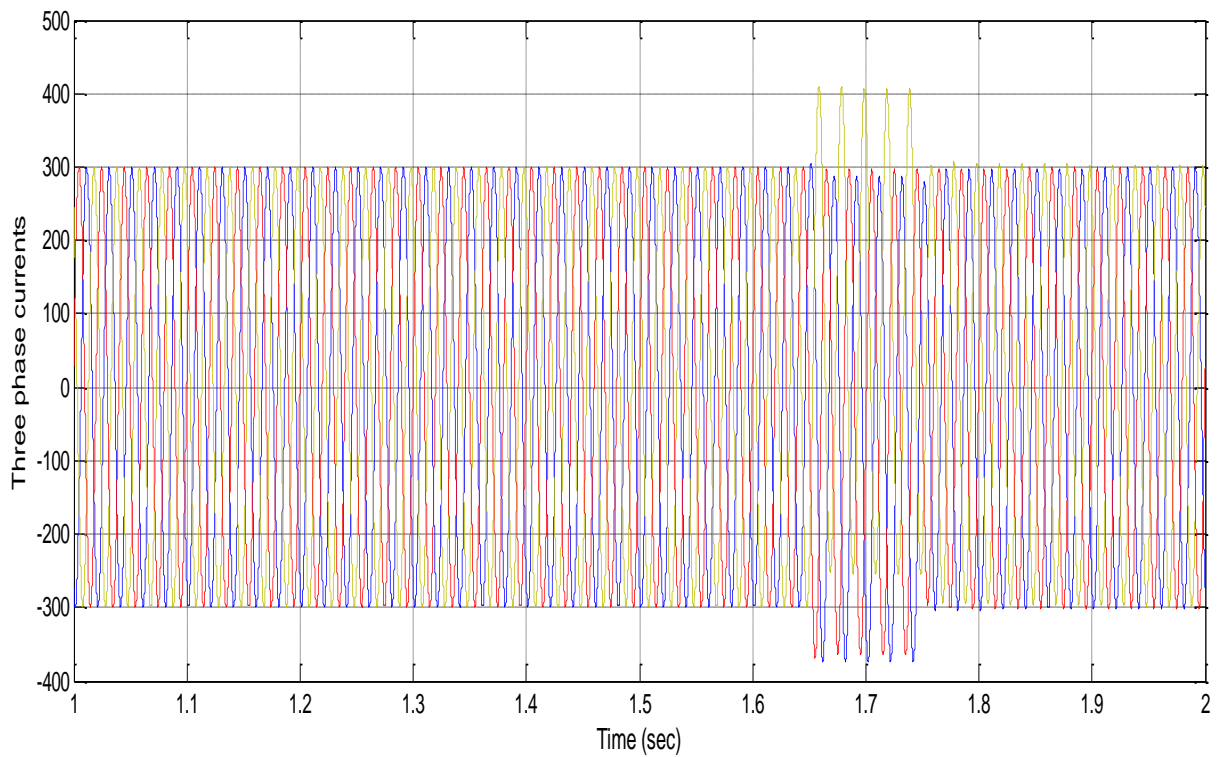

Figure 7 The current at FINT W

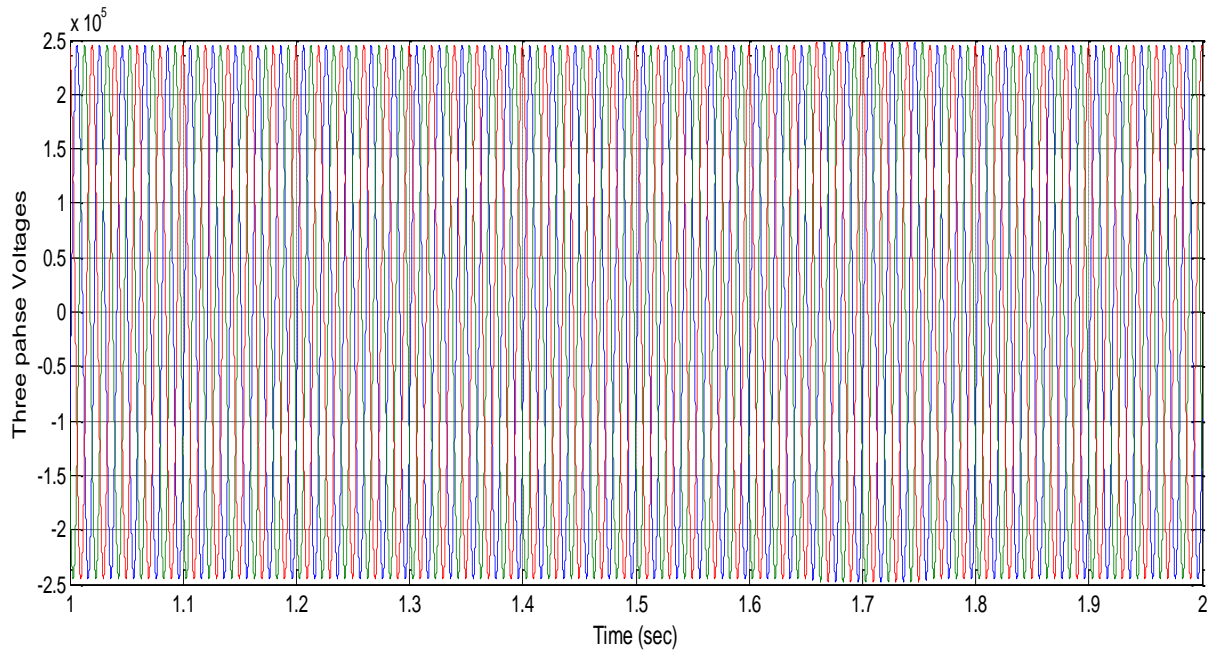

Figure 8 The voltage at FINT W

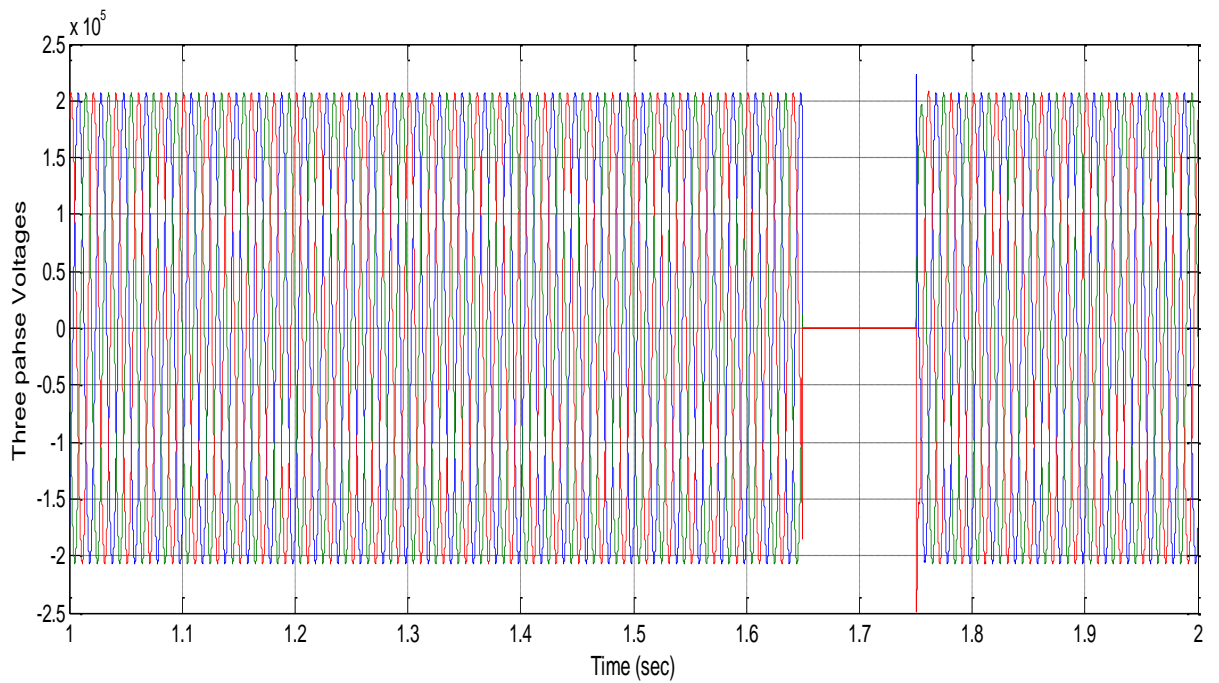

Figure 9 The voltage at JABR W

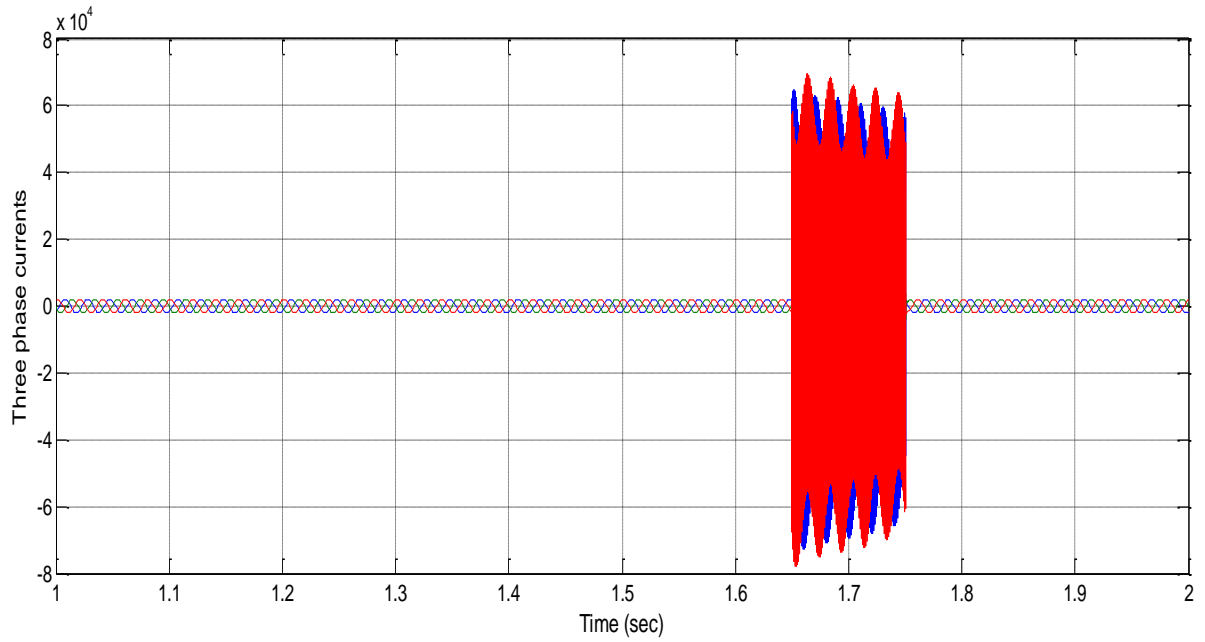

Figure 10 The current at JABR W

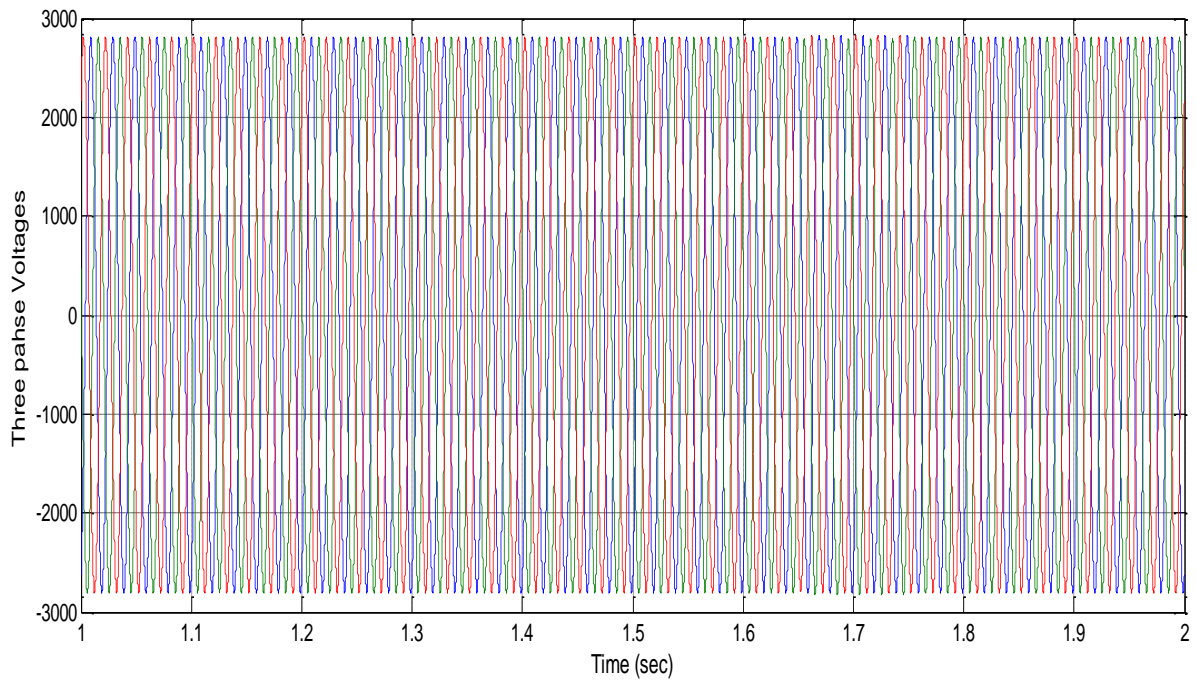

Figure 11 The current at JABR W

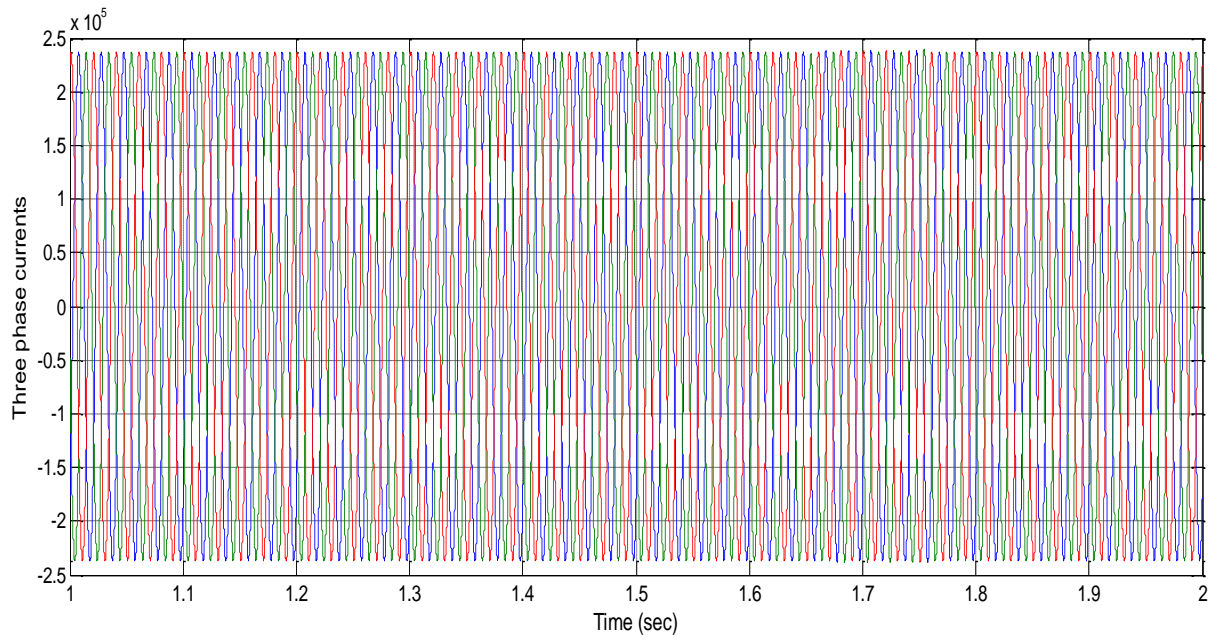

Figure 12 The voltage at JABR W

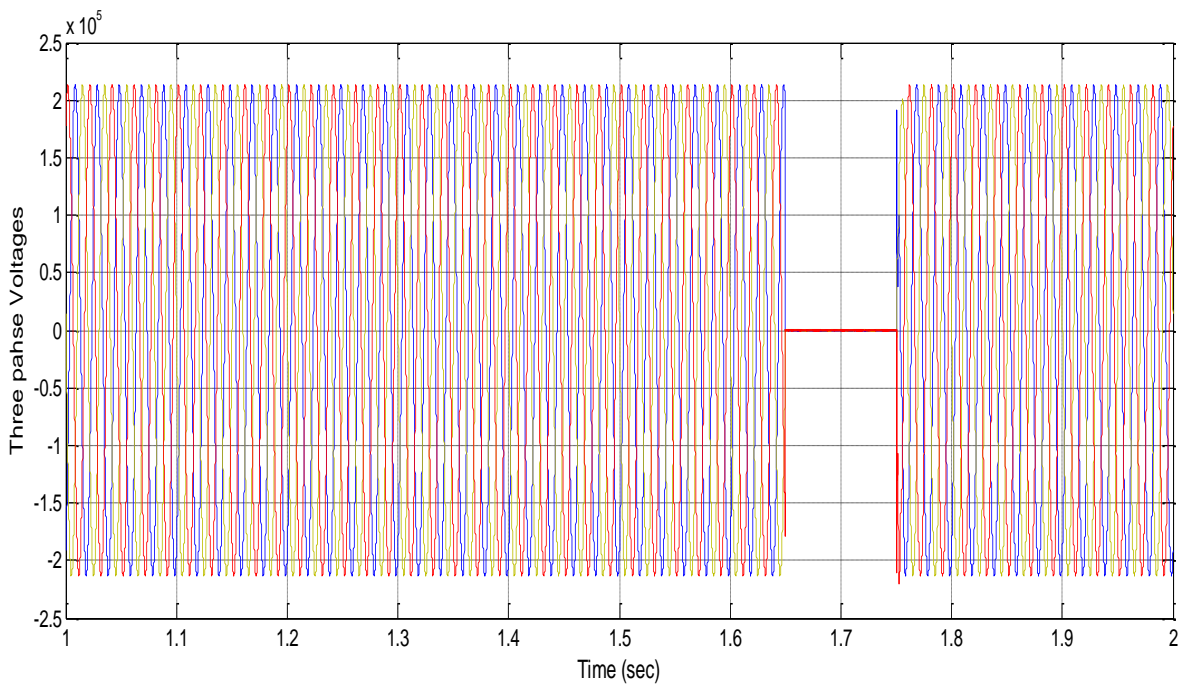

Figure 13 The voltage at FNTS W

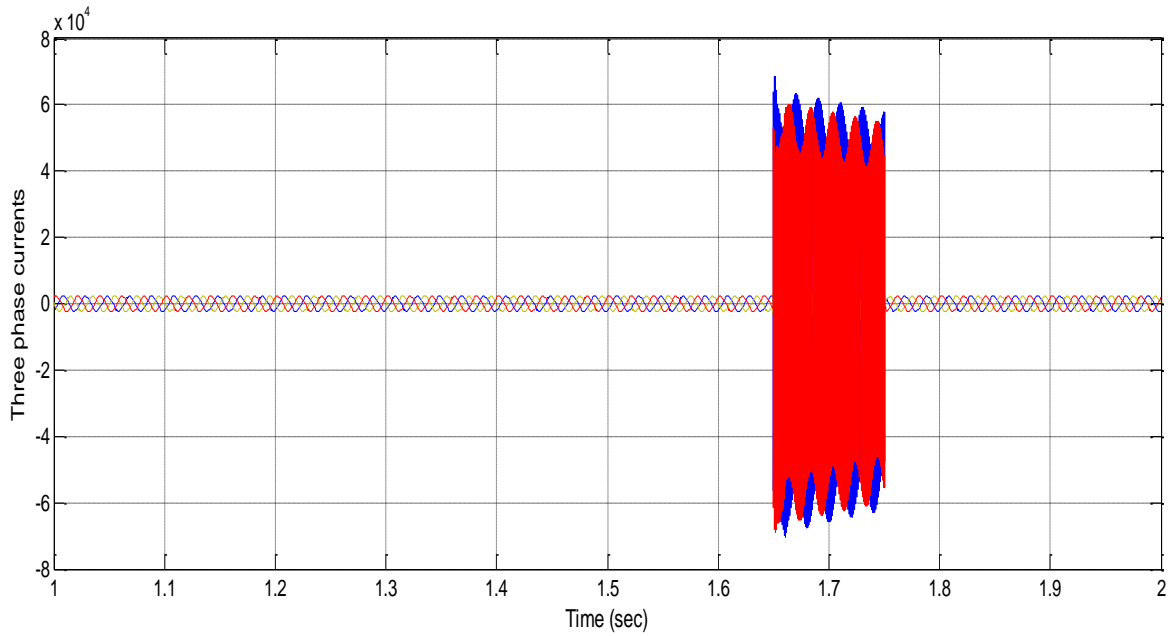

Figure 14 The fault current at FNTS W

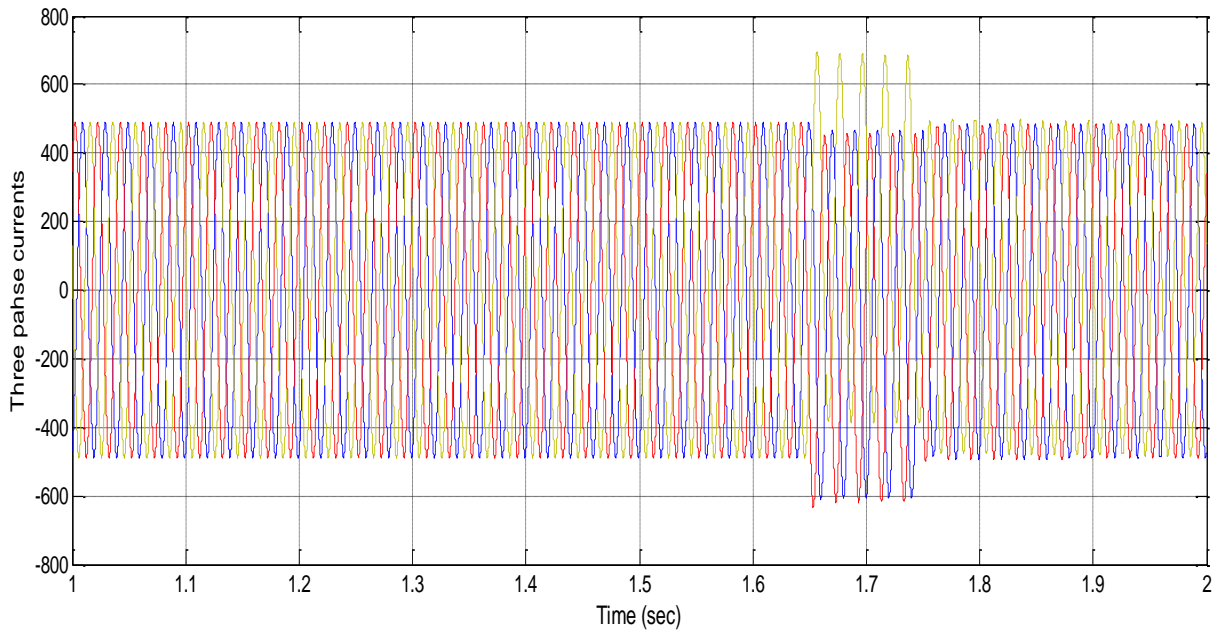

Figure 15 The current at SLPY W

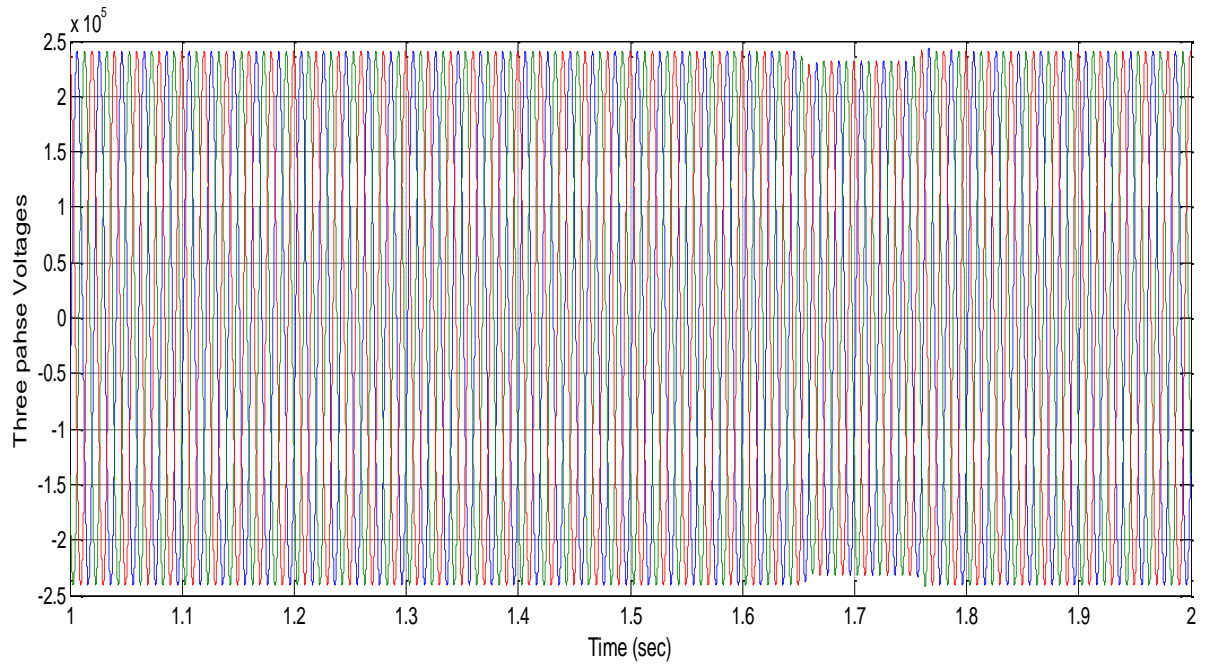

Figure 16 The voltage at SLPY W

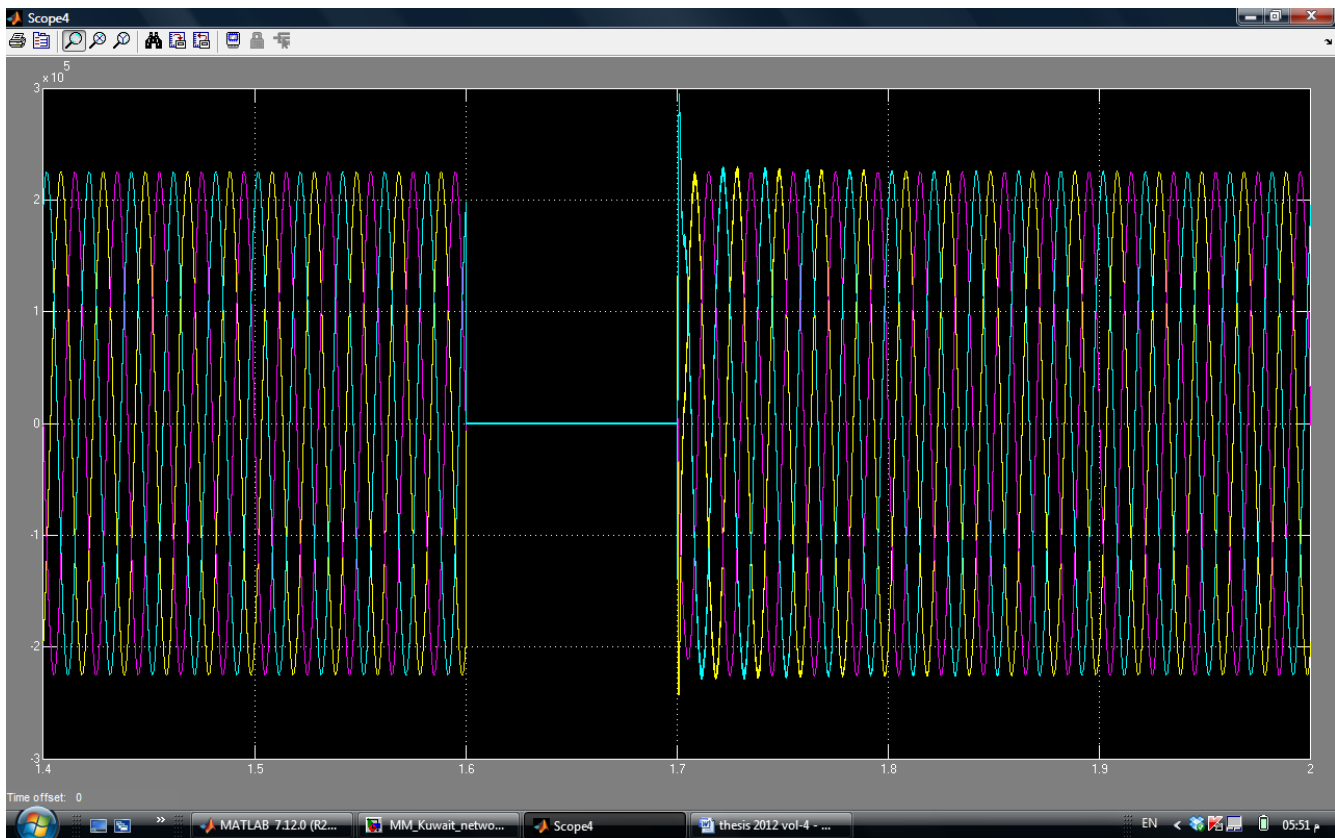

Figure 17 The fault voltage at JABR W

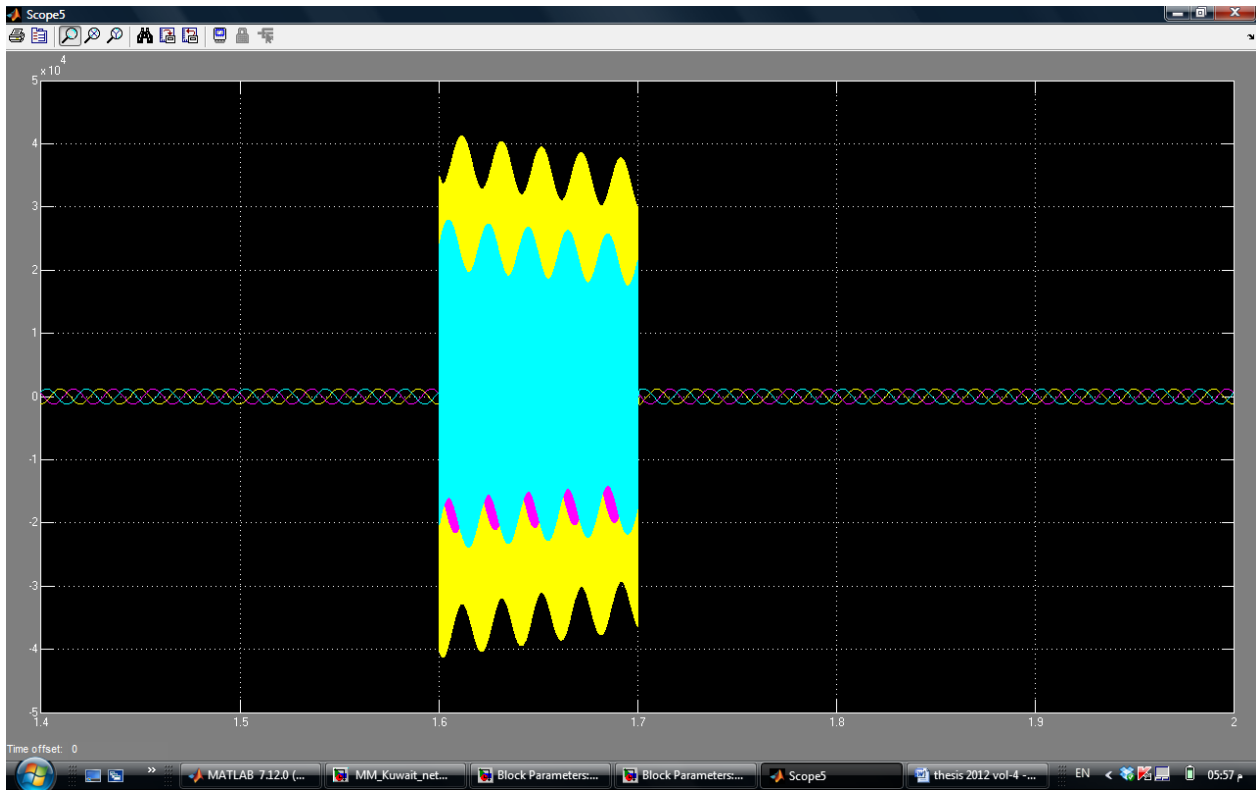

Figure 18 The fault current at JABR W

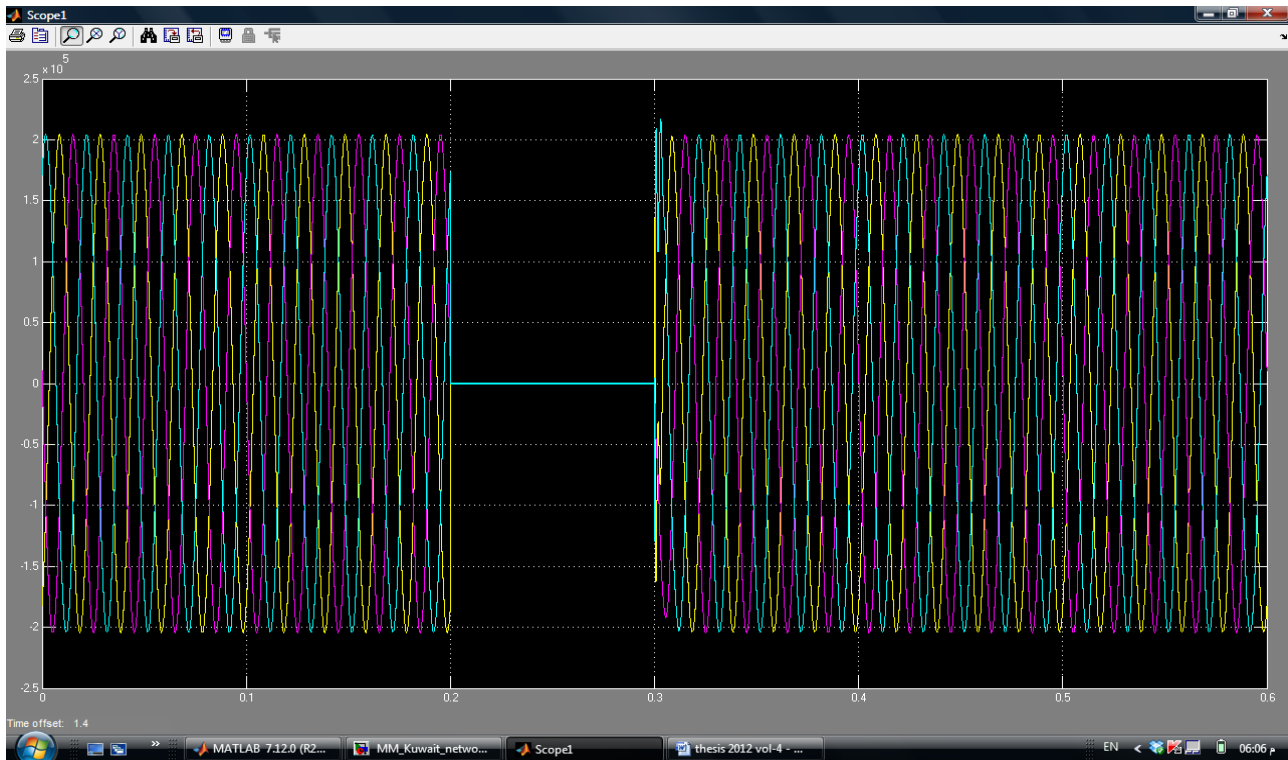

Figure 19 The fault voltage at FNTS W

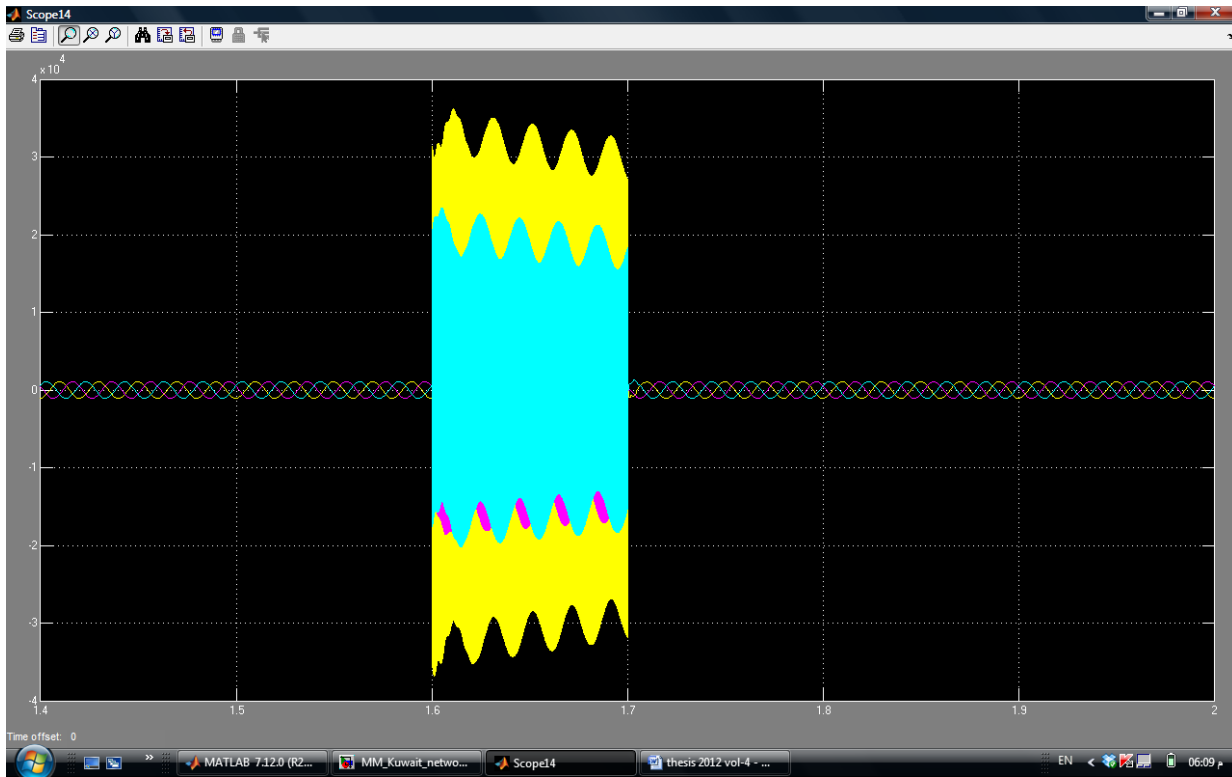

Figure 20 The fault current at FNTS W