

Experimental Investigation of Punching Shear on FRP Strengthened Slab

Mohd Tanjeem Khan¹, Md. Raja¹, Md. Sawood Ansari¹, Adib Maaz Ansari¹, Khan Rahim Saud¹,
Umarfarook H. Momin² and Shaikh Ibrahim³

¹Under Graduates and ³Assistant Professor

Civil Department, Jamia Institute of Engineering & Management Studies

Akkalkuwa, Maharashtra

²PG Scholar, Civil Department,

Padmabhooshan Vasantraodada Patil Institute of Technology

Sangli, Maharashtra

India

ABSTRACT

Punching in slabs is generally seen by the application of concentrated loads or to the presence of columns. One of the major phenomenon related to flat slabs is its punching shear capacity at slab column connection. Provided that bending capacity is installed, punching shear failure is due to the development of a truncated cone-shaped surface at the slab-column connection. Frequently, there is the need to strengthen existing flat slabs against punching shear failure. However many research works have been done on punching shear. Moreover, we want to know the behavior of RC flat slab under FRP material against punching shear. The effect of FRP bars against punching shear is checked.

The objective of the current study was to explain the feasibility of RC flat slab to examine the application of steel rods, FRP rebar on the improving of punching shear. Extensive applications of the fiber-reinforced polymer (FRP) as new construction materials have been recently accomplished. FRP materials are lightweight, high strength, and no-corrosive materials. By virtue of these advantages, there is a wide range of recent, current, and potential applications of these materials that cover both new and existing structures. Among different types of FRP materials, a fiber-reinforced polymer (FRP) is used extensively in the structural engineering field. This study was carried out to examine the viability of using FRP bars for the punching shear strengthening of the slab.

Key Words: Punching Shear, Basalt Fibre Reinforced Polymer bar, Steel Bar, Reinforced concrete slab.

1. INTRODUCTION

1.1 General

Throughout the world, an increasing number of reinforced concrete (RC) structures are being assessed as unsafe. The reasons for this include loads greater than the design capacity arising from alteration; new stringent design codes requirements, especially for earthquakes resistance and, in some cases, deterioration of the structural members. Such structures must be strengthened or retrofitted in order to serving their intended purpose.

In general, concrete structures need strengthening for the following reasons:

- To increase live-load capacity for buildings or bridges to meet new use requirements.
- To add reinforcement to a member that has been under designed or wrongly constructed.
- To improve seismic resistance, by improving the member behaviour, or improving continuity between members.

- To replace or supplement reinforcement lost by impact or corrosion.
- To improve the explosion resistance.

1.1.1 Punching Shear

The punching shear is a failure mechanism in structural members like slabs and foundation by shear under the action of concentrated loads. The action of concentrated loads is on a smaller area in the structural members. In most cases, this reaction is the one from the column acting against the slab. Eventually the slab will fail. One possible method of failure is that the load punches through the slab.

Some examples of the occurrence of concentrated loads on a slab are a column, particularly on a pad foundation, and wheel loads. This same type of failure could also happen in another way. Turning the structure upside down we get a flat slab supported by a column, where there is a high concentration of shear force around the column head.

When the total shear force exceeds the shear resistance of the slab, the slab will be pushed down around the column, or this can be viewed as the column being punched through the slab.

Punching shear failure mechanism is observed in normal floor slabs, flat slabs, and in the foundation slabs below the column. In pad foundations, where weight and depth are not so critical, it's effects are satisfied by providing sufficient depth.

1.1.2 Carbon Fibre Reinforced Polymer (CFRP)

Carbon fibre reinforced polymer, carbon fibre reinforced plastic or carbon fibre reinforced thermoplastic (CFRP, CRP, CFRTP or often simply carbon fibre, carbon composite or even carbon), is an extremely strong and light fibre-reinforced plastic which contains carbon fibres. The spelling 'fibre' is common in British Commonwealth countries. CFRPs can be expensive to produce but are commonly used wherever high strength-to-weight ratio and rigidity are required, such as aerospace, automotive, civil engineering, sports goods and an increasing number of other consumer and technical applications.



Figure1.1: CFRP Bars

CFRPs are composite materials. In this case the composite consists of two parts: a matrix and reinforcement. In CFRP the reinforcement is carbon fibre, which provides the strength. The matrix is usually a polymer resin, such as epoxy, to bind the reinforcements together. Because CFRP consists of two distinct elements, the material properties depend on these two elements.

1.1.3 Glass Fibre Reinforced Polymer (GFRP)

Fiberglass (US) or fibreglass (UK) is a common type of fibre-reinforced plastic using glass fibre. The fibres may be randomly arranged, flattened into a sheet (called a chopped strand mat), or woven into a fabric. The plastic matrix may be a thermoset polymer matrix – most often based on thermosetting polymers such as epoxy, polyester resin, or vinyl ester - or a thermoplastic.



Figure1.2: GFRP Bars

Cheaper and more flexible than carbon fibre, it is stronger than many metals by weight, and can be molded into complex shapes. Applications include aircraft, boats, automobiles, bath tubs and enclosures, swimming pools, hot tubs, septic tanks, water tanks, roofing, pipes, cladding, casts, surfboards, and external door skins.

Other common names for fibreglass are glass-reinforced plastic (GRP), glass-fibre reinforced polymer (GFRP). Because glass fibre itself is sometimes referred to as "fibreglass", the composite is also called "fibreglass reinforced plastic." This article will adopt the convention that "fibreglass" refers to the complete glass fibre reinforced composite material, rather than only to the glass fibre within it.

1.1.4 Basalt Fibre Reinforced Polymer (BFRP)

Basalt fibre is a material made from extremely fine fibres of basalt, which is composed of the minerals plagioclase, pyroxene, and olivine. It is similar to fibreglass, having better physicomechanical properties than fibreglass, but being significantly cheaper than carbon fibre. It is used as a fireproof textile in the aerospace and automotive industries and can also be used as a composite to produce products such as camera tripods.

Basalt fibre is made from a single material, crushed basalt, from a carefully chosen quarry source. Basalt of high acidity (over 46% silica content) and low iron content is considered desirable for fibre production. Unlike other materials, such as glass fibre, essentially no materials are added. The basalt is simply washed and then melted.

Basalt fibre composite tendons with high strength, light weight, alkali, acid and resistance to corrosion of natural elements such as excellent physical and chemical properties. At the same time, the thermal expansion coefficient of basalt fibre composite tendons is similar to that of concrete, which ensures the simultaneous deformation of concrete and reinforcement.



Figure1.3: BFRP and Steel Bars

Basalt fibre is a kind of natural inorganic nonmetallic material, which can play an important role in many fields such as national defense construction, transportation, construction, petrochemical, environmental protection, electronics, aviation, spaceflight etc, compared with common carbon fibre and other fibres. Because of its good electrical insulation and non-magnetic properties, basalt fibre composite ribs can be used as reinforcing bars instead of reinforcing bars in structures with special requirements, such as anti-radar interference, and are currently used in many seismic stations in China. The effect is very significant.

The manufacture of basalt fibre requires the melting of the quarried basalt rock at about 1,400 °C (2,550 °F). The molten rock is then extruded through small nozzles to produce continuous filaments of basalt fibre. There are three main manufacturing techniques, which are centrifugal-blowing, centrifugal-multiroll and die-blowing. The fibres typically have a filament diameter of

between 9 and 13 μm which is far enough above the respiratory limit of 5 μm to make basalt fibre a suitable replacement for asbestos. They also have a high elastic modulus, resulting in excellent specific strength—three times that of steel.

1.2 MAIN CHARACTERISTICS OF BFRP

As a new composite material FRP tendon compared with the traditional, has the following characteristics:

1. High tensile strength. FRP tendons tensile strength significantly more than ordinary steel and high strength steel wire strength almost. So if want to make full use of the strength of FRP tendons, generally need to exert prestress.
2. The stress-strain curves of the FRP tendons are always straight and there is no obvious yield step. This is obviously different from the ordinary steel, FRP tendons is one of the important characteristics.
3. The density is small. The density of various FRP tendons is only 16% ~ 25% of the reinforcement, which will help to reduce the weight of the structure, especially in the suspension bridge.
4. Good electromagnetic insulation. For some special requirements of the building, such as radar stations. As the existence of reinforced concrete structure of the whole structure of the electromagnetic field will be detrimental to the use of the impact, and FRP tendons are nonmagnetic materials, used to replace the steel is very appropriate.

As one of the types of FRP tendons, the basalt fibre reinforced polymer(BFRP) have these advantages. At the same time, basalt fibre composite ribs processed by basalt fibre have the following advantages:

1. **Excellent mechanical properties**
Basalt fibre tensile strength generally can reach 2000MPa, elastic modulus can reach about 90GPa, basalt fibre softening point of 960°C, its strength at high temperature can maintain strength for a long time.
2. **Stable chemical properties**
Basalt fibre has a high alkali resistance to acid, in cement can maintain a high degree of stability, alkali resistance is much better than glass fibre.
3. **Outstanding high temperature characteristics**
Basalt fibre at 400 °C temperature, the fracture strength can be maintained 85%, 600 °C in the work, the fracture strength can still maintain about 80%. Therefore, in addition to basalt fibre can be used for high-temperature insulation materials, but also can be used as liquid nitrogen and other containers or equipment, the most effective ultra-low temperature insulation material.
4. **Good dielectric properties**
Basalt fibre volume resistivity higher than the glass fibre one order of magnitude, containing only 20% less than the conductive oxide.
5. **A good resin composite capacity**
Basalt fibre and a variety of resin composite, than the glass fibre and carbon fibre has a better adhesive strength.

2. PROJECT OBJECTIVES

- To explain the feasibility of RC flat slab to examine the application of steel rods, FRP rebar on the improving of punching shear.
- To check the feasibility of RC flat slab by using different material.
- To know the behaviour of RC flat slab under FRP material against punching shear.
- To compare the results computed from the experimental analysis.
- To suggest best suited material with response of different parameters.
- To evaluate cost analysis.

3. LITERATURE SURVEY

3.1 Punching Shear

1. **Husain Abbas, Aref A. Abadel, Tarek Almusallam, Yousef Al-Salloum (2015)**

Reference [7] was abstracted that Punching shear failure of reinforced concrete (RC) slabs is a major concern for the structural designers of buildings and bridges. This type of failure is more common in bridge decks supported by girders under the action of

repeated wheel loads. The bridge decks are often strengthened for flexure by external bonding of Fiber Reinforced Polymer (FRP) sheets but the consequent enhancement in shear strength is generally low and not well known.

One of the main concerns related to two-way flat slabs is the punching shear capacity at slab column connection, which is subjected to a very complex three-dimensional stress state. Punching shear failure is hence characterized by the development of a truncated cone shaped surface at the slab-column connection. Punching shear can thus result from a concentrated load or reaction acting on a relatively small area, called the loaded area, of a slab or a foundation. This type of failure is usually both brittle and catastrophic since it may generate the global collapse of the structure due to the increasing load transfer to neighboring columns and to the slabs located underneath. The load carrying capacity of reinforced concrete (RC) slabs may be compromised for a number of reasons, including structural damage, design errors, building code changes and alteration of functional use.

The slab-column connection of a flat plate is susceptible to punching shear failure. Once punching shear failure occurs, the overall resistance of the structure against gravity load is considerably reduced, which causes the separation of the slab and column, and might even cause progressive collapse of the whole structure.

3.2 FRP Materials

1. Elsanadedy (2011)

Reference [5] was found that there are number of fibers which may be used for strengthening applications *viz.* CFRP, GFRP, BFRP, SFRP, etc. All fibers have a linear elastic response up to ultimate load, with no significant yielding. Many previous studies have examined the punching shear strength of FRP strengthened RC slabs; however, there are some theoretical deficiencies in the conventional theory, which are not able to explain the influence of FRP strengthening on punching resistance of RC slabs.

FRP materials are nowadays commonly used for the strengthening of structural RC elements. There are several studies on flexural strengthening of RC slabs using externally bonded FRP sheets. However, the FRP strengthening technique for punching shear failure is fairly new, with little research reported in this area.

2. G. I. Khaleel, I. G. Shaaban, K. M. Elsayedand, and M. H. Makhlof (2013)

Reference [6] was investigated the use of FRP in strengthening concrete slabs in flexure is done by bonding it to the tension face of the slabs. The use of FRP for strengthening the flat slabs against punching shear can be considered as a new application. This research shows the results obtained from an experimental investigation of 4 half-scale two-way slab-column interior connections, which were constructed and tested under punching shear caused by centric vertical load. The research included one unstrengthened specimen, which considered as control specimen, one specimen strengthened with steel links, one specimen strengthened with external stirrups made from Glass Fiber Reinforced Polymer (GFRP), and one specimen strengthened with external stirrups made from Carbon Fiber Reinforced Polymer (CFRP). So, the type of strengthening material is the basic parameter in this study. The experimental results showed a noticeable increase in punching shear resistance and flexural stiffness for the strengthened specimens compared to control specimen. Also, the strengthened tested slabs showed a relative ductility enhancement. Finally, equations for punching shear strength prediction of slab-column connections strengthened using different materials (Steel, GFRP & CFRP) were applied and compared with the experimental results.

3.2.1 Carbon Fiber Reinforced Polymer (CFRP)

1. Carlos Moreno, Débora Ferreira, Abdelkrim Bennani, Ana Sarmiento, and Michel Noverraz (2015)

Reference [3] was examined that the use of carbon fibre reinforced polymers (CFRP) on structural repair and strengthening has continuously increased during the last years due to the following main advantages of this composite material when compared to conventional materials like steel and concrete: low specific weight, easy installation, high durability and tensile strength, electromagnetic permeability, and practically unlimited availability regarding size, geometry and dimensions (ACI 2008). The most widely used technique aiming to increase load carrying capacity is to apply CFRP plates on the tension surface of the RC slab as externally bonded (EB) reinforcement. CFRP laminates and sheets are generally applied on the faces of the elements to be strengthened configuring which is commonly designated as the EB reinforcing technique. The research carried out up to now has revealed that this method cannot mobilize the full tensile strength of CFRP materials due to the occurrence of premature debonding phenomenon. Due to the fact that CFRP is often directly exposed to the weathering conditions the reinforcing performance of this technique should be accounted for. EB systems are also vulnerable regarding fire action and vandalism acts. Alternatively, the near surface mounted (NSM) technique, which consists of cut-in openings strengthened with CFRP materials, can be used.

3.2.2 Glass Fiber Reinforced Polymer (GFRP)

1. Chen and Li (2005)

Reference [4] was introduces used of Glass Fiber Reinforced Polymer (GFRP) laminates for the shear strengthening of slabs. They showed that the flexural strengthening of slabs by external bonding of GFRP laminates can increase the punching strength, significantly. However, GFRP laminates were more effective for the slabs with low steel reinforcement ratios. They proposed analytical equations to calculate the punching strength of strengthened slabs.

3.2.3 Steel Fiber Reinforced Polymer (SFRP)

1. Nguyen-Minh(2011)

Reference [10] was studied that they studied behavior and capacity of steel fiber reinforced concrete (SFRC) flat slabs of different dimensions. In addition, **Amen Agbossou** studied the experimental and theoretical behavior of slabs strengthened by FRP. The experimental results show that FRP significantly increases punching failure stress, resulting in a reduction of slab rotation around the loading column. The theoretical investigation presents a finite element model for the bending of strengthened slabs.

Nguyen-Minh performed an evaluation of accuracy of existing models and formulas in previous studies that used to predict punching shear resistance of steel fiber reinforced concrete (SFRC) that results from the evaluation show that the existing formulas gave inaccurate results with a large scatter in comparison with the testing results. Also, Maya et al. presented a mechanical model for predicting the punching strength of SFRC slabs as well as conventional reinforcement. This was validated against a wide number of available experimental data and its accuracy was verified.

3.2.4 Basalt Fiber Reinforced Polymer (BFRP)

1. Marek Urbanski, Andrzej Lapko, Andrzej Garbacz (2013)

Reference [8] was evaluates the basalt bars of BFRP group (basalt fiber reinforced polymer) have a number of advantages comparing to steel reinforcement and other FRP composites, such as glass GFRP (glass fiber reinforced polymer) or carbon CFRP (carbon fiber reinforced polymer). The chemical composition of basalts, which are made BFRP basalt fiber is somewhat different. In addition to the chemical composition, mechanical properties of basalt fibers originating from different sources are varied, probably due to the different chemical components and processing conditions such as the temperature of the fiber production. Basalt fiber tensile strength tends to increase from 1.5 to 2.9 GPa as the production temperature increases within the range of 1200 ~ 1375°C. This is due to the increase in the proportion of crystal nuclei basalt at lower temperatures. Basalt fiber Young's modulus ranging between 78 and 90 GPa, depending on the source, the highest values of BFRP modulus 90 GPa was reported in Russia. Most reports indicate, that comparing to glass, the basalt fiber has higher or comparable modulus and strength , and there have been reported some cases of significantly lower strength of basalt fiber than it was declared. In addition to good mechanical properties, basalt has a high chemical and thermal stability, good thermal, insulating, electrical and sound properties. Basalt thermal insulation is three times greater than the asbestos' one. Due to good insulating properties, basalt is successfully used for fire protection. Furthermore, basalt fibers have 10 times better electrical characteristics - insulating than glass fibers. Basalt fibers are also significantly better chemically resistant than glass fibers, particularly in a strongly alkaline.

2. Xiao-Chu WANG, Tian-Shi RONG and Liu XIAO(2017)

Reference [12] was concluding that Basalt fiber and concrete are similar in chemical composition, so BFRP material has good compatibility with concrete, and has good alkali corrosion resistance. As the basalt fiber has good alkali resistance, the basalt fiber composite ribs made of basalt fiber can replace the ordinary steel bar and form the BFRP reinforced concrete system. It can be used to study the tensile and bending experiments of concrete beams.

In the field of civil engineering, basalt sheet as a complete replacement or partial substitution of carbon fiber products are mainly used in structural reinforcement, a large number of practical projects have been used, and the effect is good. Especially in the basalt fiber reinforced plastic columns experimental study shows that the performance of basalt fiber reinforced columns to achieve even more than the use of carbon fiber reinforced column performance, and its price is only 19% of carbon fiber.

Basalt fiber composite tendons can be used for anchor reinforcement for slope and other parts, and because of its good electrical insulation and non-magnetic, can have special requirements in the structure (anti-radar interference or sensitive electrical test equipment structure) As a steel bar to replace the use of force, the current structure is also a number of seismic stations in the pilot use, the effect is good.

3. Ms. S. Nandhini & Ms. S. Malarvizhi (2017)

Reference [9] was abstracted that concrete is the most widely used construction material in civil engineering industry because of its high structural strength and stability. Basalt fiber reinforced polymer (BFRP) application is very effective ways to repair and strengthen structures that have become structurally weak over their life of the span. They are made from basalt rock, are very light and have tensile strength, over twice as high as steel. BFRP Repair systems provide an economically viable alternative to traditional repair systems and materials. BFRP bars have high tensile strength and low elastic modulus compared with steel bars. The bond strength between BFRP bars and concrete is similar to the bond strength of steel bars and concrete and shows good bond performance. The superior properties of polymer composite materials like high corrosion resistance, high strength, high stiffness, excellent fatigue performance and good resistance to chemical attack etc., has motivated the researchers and practicing engineers to use the polymer composites in the field of rehabilitation of structures.

4. EXPERIMENTAL PROGRAMME

4.1 Test Specimens

Current experimental programme includes 3 RC square concrete slab specimens 700×700 mm² wide and 110 mm height, with central loading point which were designed so as the bending capacity prevail over the punching shear strength in order for slabs to fail in shear.

Reinforcement on the tension side of the specimens consisted of 8 mm deformed bars with a spacing of 100 mm starting from the edges and giving 200 mm spacing at center for both orthogonal directions, whereas compression reinforcement consisted of 8 mm deformed bar with spacing same as in the tension side for both orthogonal directions. In order to bond the reinforcement bars between the tension side and compression side stirrups of 6 mm of diameter were used of size 6”x3”inch.

Two-way slabs with low or medium reinforcement ratios tend to fail in flexure rather than in punching shear. For two-way slabs that have reinforcement ratios of 1.0% and more, the mode of failure tends to be the punching shear type of failure.

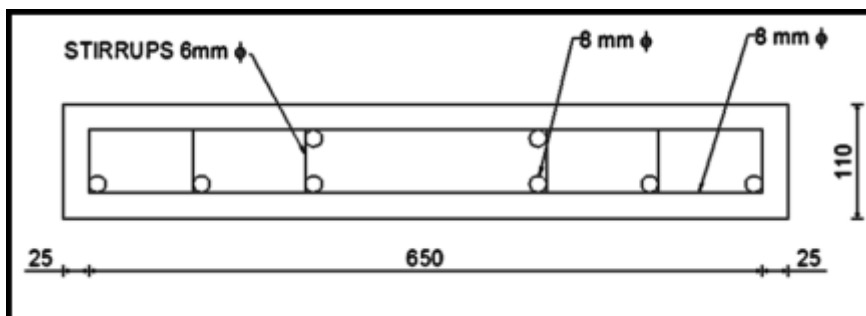

Figure4.1: Cross-Section of Slab

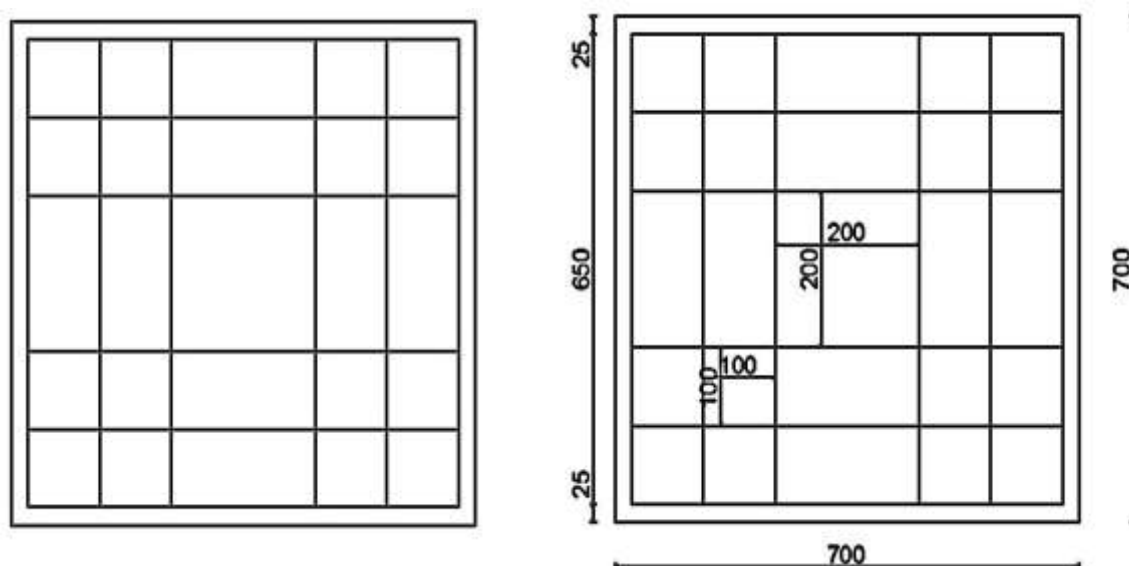

Figure4.2: Plan View of Slab

4.2 Materials Properties

4.2.1 Concrete

The concrete was designed to have a 28-day cube compressive strength of 25 MPa using 20 mm maximum aggregate size and a 0.48 free water-cement ratio.

4.2.1.1 Cement

The cement we used in our project work was UltraTech OPC 43 grade. Cement in concrete act as a binding material that haden after the addition of water.it plays an important role in construction sector. The cement is conforming to IS 8112:1989.

4.2.1.2 Sand

The sand we used in our project work was manufactured sand (M-Sand). M-sand is manufactured by proper crushing of aggregates into finer materials of required particle size (generally using VSI technology). The sand obtained will better confirm to the zone-II grading standards at all time. The sand is conforming to IS 383:1970.

4.2.1.3 Aggregate

The aggregate we used in our project work was passed by 20mm IS Sieve and retain by 10 mm IS Sieve.

4.2.2 Steel

The steel used in our project was of HYSD rebar viz. Grade Fe415

We have used 8 mm ϕ bar in the tension side as well as in the compression side.

And stirrups of 6 mm ϕ .

Table 4.1: Material properties of bending and shear reinforcement steel

Diameter (mm)	Yield strength (MPa)	Ultimate strength (MPa)	Young modulus (GPa)
8	535	650	200

4.2.3 BFRP Bar

Basalt fiber is a material made from extremely fine fibers of basalt, which is composed of the minerals plagioclase, pyroxene, and olivine. It is similar to carbon fiber and fiberglass, having better physico mechanical properties than fiberglass, but being significantly cheaper than carbon fiber. It is used as a fireproof textile in The aerospace and automotive industries and can also be used as a composite to produce products such as camera tripods.

Basalt is a natural, hard, dense, dark brown to black volcanic igneous rock originating at a depth of hundreds of kilometers beneath the earth and resulting the surface as molten magma. And its gray, dark in colour, formed from the molten lava after solidification. The production of basalt fiber consists of melt preparation, extrusion, fiber formation, application of lubricates and finally winding. This method is also known as spinning.

Table 4.2: Basalt Fibre Physical/Mechanical Properties

Basalt rebar technical data published in National Rebar Standard The standard code is: JT/T 776.4-2010		
Item	Basalt Fiber Rebar	
Density (g/cm ³)	1.9 - 2.1	
Tensile Strength (MPa)	Not less than 750	
Tensile Elastic Modulus	Not less than 4.0 X 10 ³	
Elongation At Break (%)	Not less than 1.8	
	Longitudinal	9 – 12
	Transverse	21 – 22
Anti- Alkali (Strength Remaining %)	Not less than 85	
Magnetic Susceptibility (4 μ X 10 ⁻⁸ Si)	Not less than 5 X 10 ⁻⁷	

Table 4.3: Material properties of bending and shear reinforcement of BFRP Rebar

Rebar Diameter (mm)	Weight (g)	Nominal Area (mm ²)	Tensile Strength (MPa)	Ultimate Force (KN)	Elastic Modulus (GPa)	Ultimate Strain (%)
8	104	50.24	1200	60.29	55.00	2.18

5. METHODOLOGY

5.1 General

The Project deals with the increase in shear capacity of concrete slabs using BFRP rebars. The BFRP rebars are light weight Material i.e. One-fourth of steel reinforcement, nonmetallic therefore highly corrosive resistance. The BFRP bars are high tensile that cannot bar bent up manually, so the four bars are cut into required Length and tied up as like conventional stirrups in Order to increase the shear capacity of concrete slab.

For the Concrete mix design slabs are casted using conventional steel and BFRP (basalt fibre reinforced polymer) bars. Three different slabs are casted i.e. normal conventional slab with steel reinforced, BFRP reinforced concrete slab These above beams

are tested for flexural strength and deflection curve under loading condition. Thus the results are compared with the calculated theoretical values as per Indian Standards.

5.2 Actual Working Procedure

- The procedure start with the selection of the materials like cement, sand and aggregate as well as steel & BFRP rebar.
- Then we have done many analytical researches for the designing of slab.
- Then we have cut the bars of steel and BFRP according to our design and made meshes for the slab of steel reinforcement and BFRP reinforcement.
- Then the materials was weighed accurately as per the calculations and properly mixed in the concrete mixer.
- Now keeping the mesh into the formwork of slab by providing necessary cover, the concrete from the concrete mixer was placed into it carefully.



Figure5.1: Steel Mesh

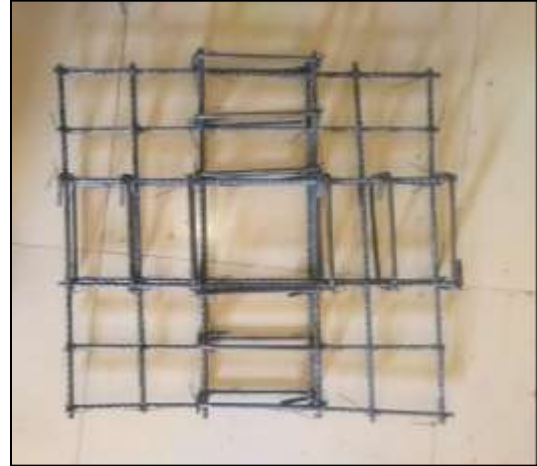

Figure5.2: BFRP Mesh

- Further the slab was undisturbed for atleast 24 hours to make the concrete hardened and thereafter the formwork was unmould and slab was placed into the curing tank.
- After the 28 days of curing, the slabs were removed from tank and perform the test for the shear capacity of slab viz. Punching shear.



Figure5.3: Test Setup

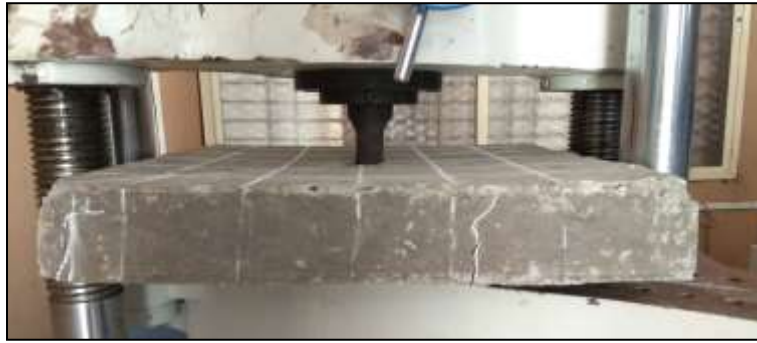

Figure5.4: Slab Specimen during applying of load



Figure5.5: Cracking Pattern

5.3 Analytical modeling

All the tested specimens failed as a result of concrete exhaustion under punching shear stress at the critical section located at a distance $d/2$ from the outermost row of punching shear reinforcement. For the prediction of the ultimate test loads, the following equation can be used to calculate the values of concrete nominal punching shear strength:

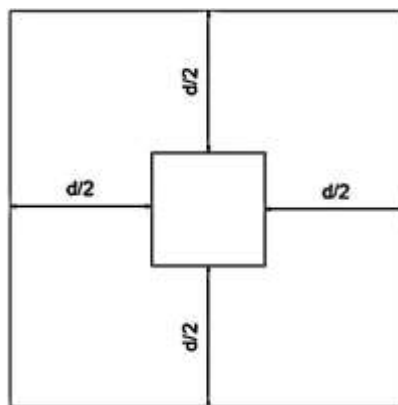

Fig5.3: Shear Diagram

$$\tau_v = \frac{V_u}{bd}$$

$$V_u = P \times [A - (B + d)^2]$$

Where, τ_v = Actual Shear Stress

V_u = Shear force due to design loads

bd = Area Resisting Shear

(b = Perimeter at critical section; d = effective depth)

- P = Pressure
- A = Area of Slab
- B = Width of column

Now, τ_c = Design shear strength of concrete is been calculated by percentage of reinforcement in concrete using IS 456:2000.

6. RESULTS

As from the objective of our project, we had assumed that the BFRP rebar would give us the satisfactory result against punching shear capacity. Hence the results that we had obtained during the testing of the slab are mentioned in this chapter. As far as testing of specimens is concern, due to the resource locally available the specimens was tested on UTM (Universal testing machine) of capacity 1000KN.

In this project we have done Punching shear capacity comparison of 2 Slabs. First slab with the reinforcement of steel rods, second slab with the reinforcement of BFRP rods. Ultimate load for steel slab is 648.02KN, BFRP slab is 857.06KN. In this comparison, we get the maximum strength in the BFRP reinforcement. BY looking at the result, using BFRP reinforcement can be effective solution for replacement of steel in reinforced concrete.

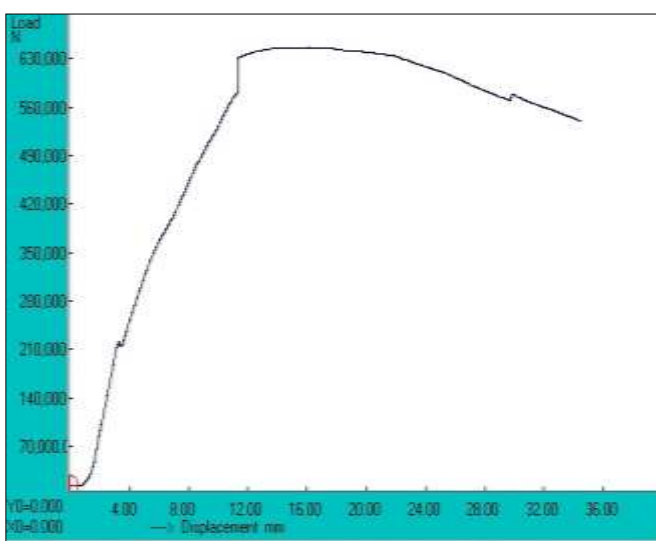

Figure6.1: Load-Displacement Curve of Steel Slab

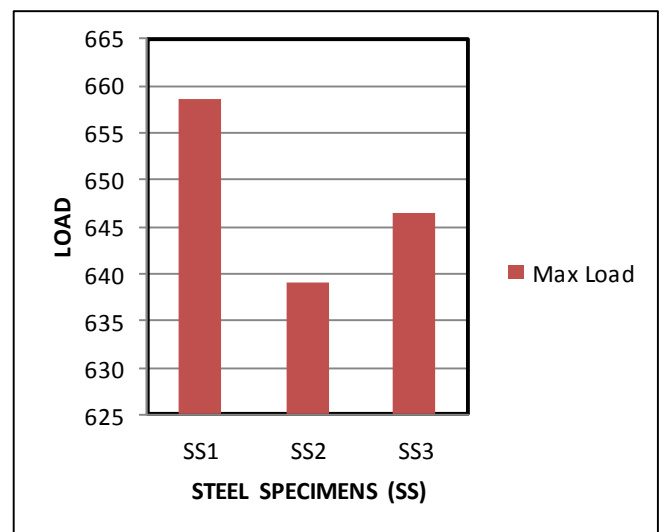

Figure6.2: Max Load Carrying By Steel Slab

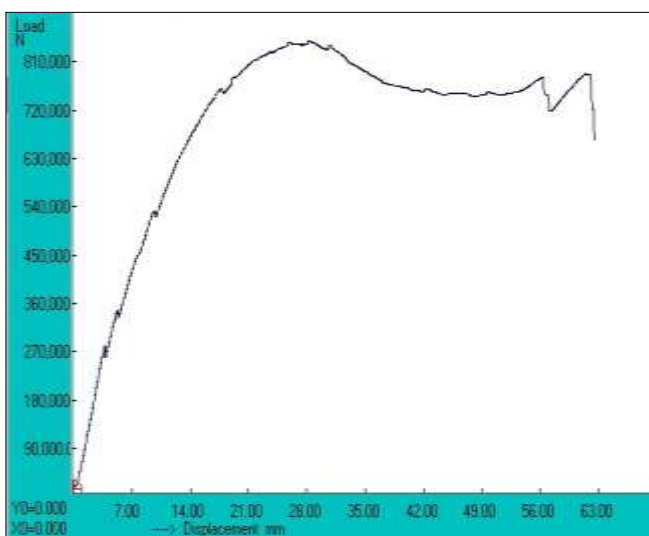

Figure6.3: Load-Displacement Curve of BFRP Slab

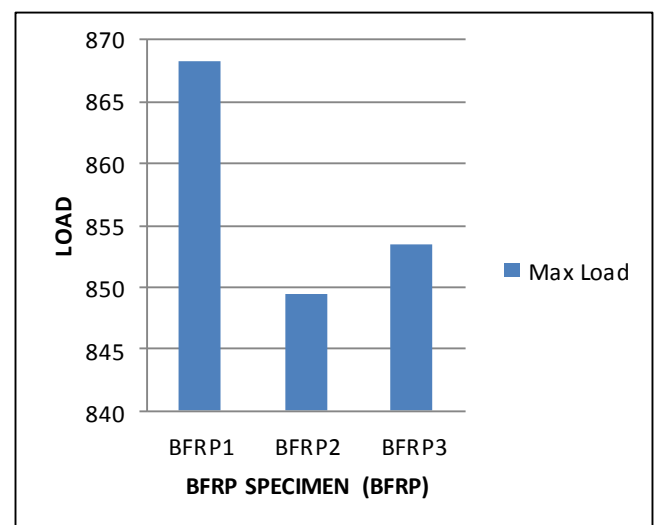

Figure6.4: Max Load Carrying By Steel Slab

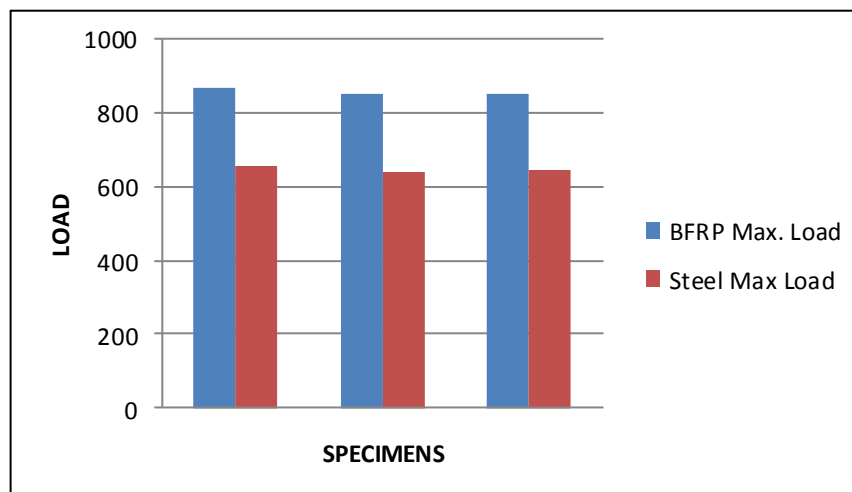

Figure6.5: Max Load Carrying by Steel & BFRP Slab

7. CONCLUSIONS & DISCUSSION

7.1 Conclusions

Based on the research work the following conclusions and recommendations can be summarized:

1. The BFRP material which we used as reinforcement in the slab is feasible to resist the shear failure i.e. Punching Shear.
2. All the specimens failed due to punching shear.
3. All the materials used in this research to strengthen the slab were effective and improved significantly the shear punching behavior in terms of initial cracking load and the ultimate carrying capacity. Using steel rods and BFRP rebar's of the same area increased the ultimate capacity by 31% to 34%.
4. As the use of BFRP material in slab has not been done yet before so this project work can be used as a base research work for further investigations/ researches on reinforcing the BFRP material in a slab or structure.
5. The BFRP rod was the best strengthening material, which led to highest improvement in the rigidity and ultimate capacity of the tested specimens.
6. The strengthened specimens, either with steel links or BFRP reinforcement, increased the number of radial cracks.
7. The distance between the column face and the surrounding failure crack was larger in case of strengthened specimens.
8. The yield strength of BFRP bar is considerably higher than that of steel. Hence the deviation in the graph between BFRP slab and Steel slab can be easily shown.
9. In our study we come to know that china has intellectual rights of BFRP & USA has intellectual rights of CFRP. But in recent days, china tried to take the intellectual rights of CFRP with many recent researches. If we Indian also tried to take the intellectual rights of BFRP to carried out various research then it is possible with proud moment.
10. If BFRP becomes locally available material then it became very cheap.

7.2 Future Scope

1. Alternate materials can be used, such as CFRP, GFRP and SFRP sheet or rebar etc. to strengthened the slab.
2. The strengthened slab with BFRP reinforcement may be test on frame machine.
3. Check the possibility and feasibility of hybrid beam.
4. The percentage of BFRP bar may be decreased or increased in order to check the resistance against the punching shear capacity.
5. The effect of punching shear on BFRP Strengthened slab may also be determined by FEM Software.

6. As Indian standard (IS) code doesn't provide us design consideration or the design procedure for the use of BFRP reinforcement in the structure. Hence Indian standard committee should provide us the IS code for the guideline of BFRP reinforcement in the structure.

REFERENCES

- [1] IS Code 456:2000.
- [2] Amen Agbossou, Laurent Michel, Manuel Lagache, Patrice Hamelin (2008), "Strengthening slabs using externally-bonded strip Composites: Analysis of concrete covers on the strengthening", *Composites Part B Engineering*, 39(7), 1125-1135
- [3] Carlos Moreno, Débora Ferreira, Abdelkrim Bennani, Ana Sarmiento, and Michel Noverraz (2015), "Punching Shear Strengthening of Flat Slabs: CFRP And Shear Reinforcement", *Concrete – Innovation and Design*, fib Symposium, Copenhagen May 18-20, 2015
- [4] Chen, C.C., Li, C.Y. (2005) "Punching shear strength of reinforced concrete slabs strengthened with glass fiber-reinforced polymer laminates", *ACI Structural Journal* 102(4):535-542.
- [5] Elsanadedy(2011), "Textile-reinforced mortar (TRM) versus FRP as strengthening material of seismically deficient RC beam-column-joints", *Journal of Composite for Construction* 15(6):920–933.
- [6] G. I. Khaleel, I. G. Shaaban, K. M. Elsayedand, and M. H. Makhlof(2013), "Strengthening of Reinforced Concrete Slab-Column Connection Subjected to Punching Shear with FRP Systems", *IACSIT International Journal of Engineering and Technology*, Vol. 5, No. 6, December 2013
- [7] Husain Abbas, Aref A. Abadel, Tarek Almusallam, Yousef Al-Salloum (2015), "Effect of CFRP and TRM Strengthening of RC Slabs on Punching Shear Strength", *Latin American Journal of Solids and Structures*.
- [8] Marek Urbanski, Andrzej Lapko, Andrzej Garbacz (2013), "Investigation on Concrete Beams Reinforced with Basalt Rebars as an Effective Alternative of Conventional R/C Structures", *Proceedings of 11th International Conference on Modern Building Materials, Structures and Techniques*, Bialystok, Poland.
- [9] Ms. S. Nandhini & Ms. S. Malarvizhi (2017), "Hybrid Reinforced Concrete Beam Using Steel and BFRP Bars", *Imperial Journal of Interdisciplinary Research (IJIR)* Vol-3, Issue-5, 2017, Chennai
- [10] Nguyen-Minh L., Rovnak M., Tran-Quoc T., Nguyenkim K., (2011), "Punching Shear Resistance of Steel Fiber Reinforced Concrete Flat Slabs", *Procedia Engineering*, 14(2011), 1830-1837.
- [11] Nigro, E., Ludovico, M. D. & Bilotta, A. (2008). "FRP-Concrete debonding: Experimental tests under cyclic actions", *Proceedings of The 14th World Conference on Earthquake Engineering*, Beijing, China.
- [12] Xiao-Chu WANG, Tian-Shi RONG* and Liu XIAO(2017), "Theoretical Study on Composite Bars of Basalt Fiber", *Proceedings of 2017 Joint International Conference on Materials Science and Engineering Application (ICMSEA 2017) and International Conference on Mechanics, Civil Engineering and Building Materials (MCEBM 2017)* ISBN: 978-1-60595-448-6, Shenyang University, Liaoning Province, Shenyang, China.