

A novel approach for hybridization of vehicles for the conservation of fuel and environment

Shivam S Verma¹, Nitin Patel¹, Anshul Kumar¹, Gurudev Singh¹, Gaurav Budakoti¹, Varun Goyal²
Gurpreet Singh¹, Akshay Khindria¹, Manoj Kr Baid¹ and Aal Arif Sarkar¹

Research Scholar¹ and Professor²

School of Mechanical Engineering

Lovely Professional University

Punjab, India

ABSTRACT

Due to the increase in the number of vehicles, pollution has increased exponentially in the near past. Various research has been done to minimize the net emission of the smoke. In this project, the use of electric powertrain in automobile systems is experienced in a different manner. The main objective was to design a car that can work under electric power to minimize the pollution level within the city and if required it could also be operated upon petroleum. Another objective was to keep to its cost as low as possible as there are already enough hybrid vehicles available but at a higher cost. This hybrid vehicles (SHEVs) combine an internal combustion engine (ICE) and an electrical energy/power source that is composed of a battery and one or two electric machines. Compared with the common hybrid electric vehicle (HEV), a SHEV has greater potential to reduce fuel consumption and reduce emissions, since it allows full electrical rear wheel driving inside the city within the speed range of 50-60 km/hr. The main emphasis of this project lies in its designing of the split hybrid pattern and the Regenerative system effectively. The other important additional feature is its power switch transmission i.e. effectively from IC engine to Electric engine or vice-versa depending on the traveling environment, inside the city (electric engine) and on highways (IC engine).

Key Words: Hybrid Vehicle, Electric Vehicle, Pollution, Emission.

1. INTRODUCTION

This is the era of technology and the technology is so advanced that we can go from one place to another in few minutes. Superbikes to Hyperloop, researchers are doing their best to minimize the transportation time without compromising with safety measures. Among all the means of transport, roadway is the most common. According to a report of world bank, there are 809, 519 and 588 vehicles per 1000 people in USA, UK and Germany respectively [1]. In order to avoid the violation of laws of thermodynamics, each and every transportation system requires some energy input. Most commonly, energy inputs are in the form of chemical energy through hydrocarbon fuels. With the combustion of fuels, there is a liberation of harmful gases like NOX & SOX which eventually effects humans' health through environment. In order to avoid this, automobile giants like BMW, Ford, Toyota and Tesla have come up with the concept of Electric and Hybrid Vehicles. Currently there are three types of Hybrid Vehicles (i) Series Hybrid, (ii) Parallel Hybrid and (iii) Series-Parallel Hybrid. A lot of research has been done on hybrid vehicles like K V Subramaniam, et.al [2] have done research on the handling of Hybrid vehicle depending upon the shifting of centre of gravity whereas R R S Bravo, et.al [3] has designed a pneumatic regenerative braking system for heavy duty hybrid vehicles. A petrol engine in a conventional car has an average engine efficiency of 17%-20% under normal driving conditions. Most of the energy in the fuel is lost as heat and a smaller part as engine friction. However, of the remaining energy out from the engine approximately 10%-12% is lost during idling and another 20%-30% is 'lost' when braking. In conclusion, only 20% of the energy supplied as fuel is actually used to move the car forward [4][5][6]. HEVs can deal with some of these energy losses using different kinds of technologies designed to harness and utilize 'lost' energy. The degrees ranging from 'mild HEV', to 'full HEV' and

'Plugin HEV' refer to the technologies used and, in general, increased degrees of fuel efficiency. In normal HEV's principle, two drives (mechanical and electrical) trains can be connected with each other, sharing some components such as the transmission and gear box. But here in this project there is no interconnection between the IC engine drive train and the Electric drive train as the trains are individually capable of driving the vehicle without any hindrance. It is known as Split Hybrid Electric Vehicle because there is splitting of power. At a time either IC engine or electric engine is providing power to the wheels. And the change of powertrain will be regulated by a controller.

2. EXPERIMENTAL/RESEARCH WORK

Increasing awareness of air quality and interest in innovative vehicles stimulate the research activity to improve the propulsion systems by reducing the vehicle emissions. Hybrid electric vehicles (HEVs) appear as the nearest forced first step in order to have reductions in both emissions as well as fuel consumption. When designing a vehicle for a specific application, the primary goal is to select the powertrain configuration that maximizes the fuel displaced and yet minimizes the sizes of components. However, the design of the split system for the HEV is based on the blended strategy, and it has a relatively short electric driving duration. Considerable improvements have been obtained in all studying area of HEVs due to the efficiency enhancement of both electrical machines and internal combustion motors. The main emphasis of the designing was completely laid on the Electric drive train with a RBS system, the main reason behind it is that since it's a split HEV and each drivetrain will individually drive the vehicle.

2.1 Mechanical Drive Train

A Maruti 800cc engine was taken and it was mounted at the front of the car. And power was transmitted to the wheels through synchronous mesh transmission system. The dimensions and specifications of the vehicle are as follows:

Table 1.1 Vehicle Dimensions and other specifications

Specification	Value
Overall Length	3340 mm
Overall Width	1440 mm
Overall height	1405 mm
Wheel base	2175 mm
Ground clearance	175 mm
Kerb weight	950 kg
Gross vehicle weight	1300 kg
Maximum IC Engine Power	37 HP @ 5000 RPM
Maximum IC Engine Torque	57 Nm @ 2500 RPM
Transmission	Manual, 4 speed gearbox
Fuel Type	Gasoline

2.2 Electric Drive Train

A 10 HP permanent magnet DC motor was used for the driving purpose. And a speed of 40-45 kmph was achieved through the motor. The designing of electric drive train has been done in consideration to the use of RBS (Regenerative Braking System) as RBS is the prime degree of hybridization of the project. The entire design drives around the RBS installation and implementation but also having the effective control on the drive train system by other components and features. The electric drive train has been placed on the rear axle. It has no interconnection with the front axle; it acts as an independent system. The designed has been done in such a way that it drives the vehicle without much effort. A schematic design of the power transmission is shown in figure 1.1.

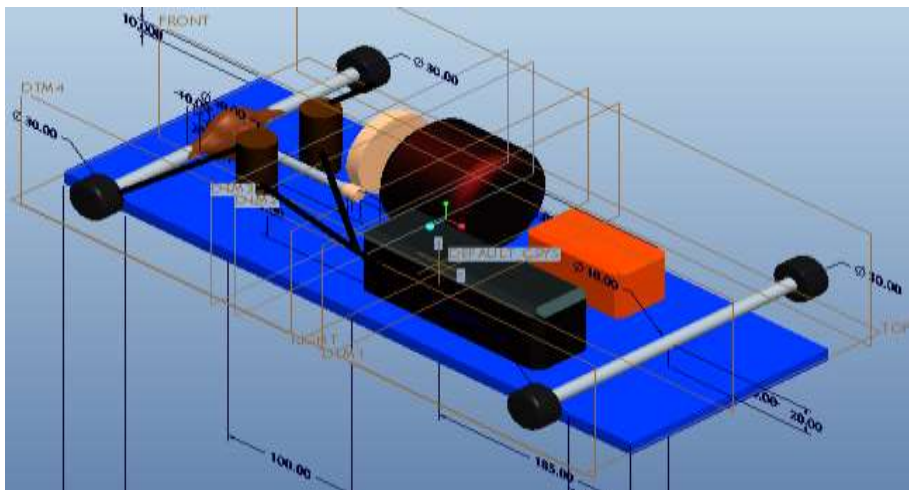

Figure 2.2.1 Schematic depiction of the power transfer from electric motor to wheels

2.3 Regenerative Braking System

A key feature in this split hybrid electric vehicles is the regenerative braking system; this system is in addition to a traditional braking system. A regenerative brake system (RBS) converts the kinetic energy, caused by the deceleration of the vehicle body, into another type of energy (e.g. electric, rotational kinetic) instead of dissipating it as heat through friction brakes. Brake energy recuperation is an important feature of electrified vehicles and will become increasingly important in future vehicle. The important additional feature of this vehicle is its Split hybridization. Split hybridization without energy recuperation promises a fuel reduction of approximately 20% in comparison with a similar sized non-hybrid vehicle. Adding brake energy recovery saves an additional 6% on fuel consumption. However, it must be emphasized that the efficiency gain, due to energy recovery, is considerably higher in urban driving than normal use on highways. This is caused by frequent moderate braking events in urban areas, which allow full regenerative brake exploitation. This provides the indirect result of reducing the hybrid vehicle’s environmentally and economically damaging emissions by the decreasing dependence on the internal combustion system. [7]

2.4 Implementation

The rear dead axle of was used for the transmission of power from electric motor to the wheels whereas front axle was used for the transmission of power from conventional IC engine to the wheels. On the rear side extra leaf spring was used in addition to master leaf spring to nullify the effect of weight of the electric motor and battery packs.



Figure 2.4.1 Rear axle with differential

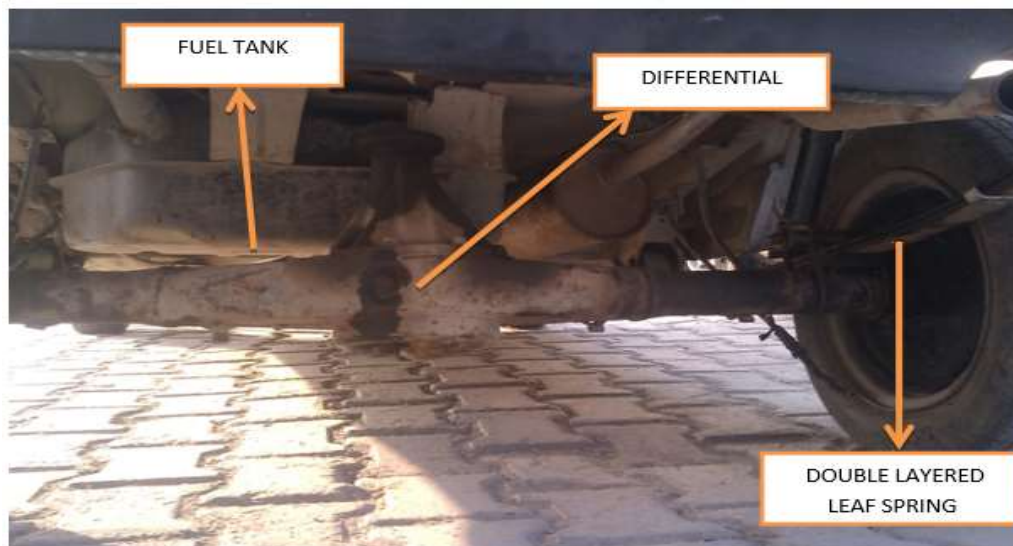

Figure 2.4.2 Mounted vertical differential setup

3. OUTCOME AND CONCLUSION OF THE PROJECT

The objective of fabrication of this vehicle was to reduce the concentrated pollution in cities by the running the car on electric powertrain. Generally, the approved top speed of a car in Indian cities is capped to 60 kmph and in some cases it is even 35 or 40 kmph also. The fabricated vehicle was easily able to run at 40 kmph at full load. It means within the cities the fabricated car can be useful as there will be significant reduction in noise and air pollution.

From economic point view, the initial cost of the car can be slightly higher than the other cars but running cost of the car will be lesser than that of conventional cars. So, payback time can be calculated by considering the average usage of the car. And petroleum fuels can be saved in this way and they can be utilized in some other applications.

ACKNOWLEDGMENT

This was successful because of the guidance from the teachers of the School of Mechanical Engineering of Lovely Professional University, Punjab. Moreover, LPU has sponsored the project and allow us to showcase our innovation at the 14th Auto Expo, which was held at The Great Indian Place, Greater Noida.

REFERENCES

- [1] The World Bank, "World Bank Data: Motor Vehicles (Per 1,000 people)", 2014.
- [2] Kesavan Valis Subramaniam, C S Nanda Kumar, Shankar C. Subramanian, "Analysis of Handling performance of Hybrid Electric Vehicles," *IFAC-PaperOnLine*, June 2018, Vol. 51, pp.190-195.
- [3] R R S Bravo, Victor Juliano De Negri, Amir Antonio Martins Oliveira, "Design and analysis of a parallel hydraulic-pneumatic regenerative braking system for heavy-duty hybrid vehicles," *Applied Energy*, September 2018, Vol. 225, pp. 60-77.
- [4] Max Boerboom, "Electric Vehicle Blended Braking maximizing energy recovery while maintaining vehicle stability and maneuverability," *Chalmer University of Technology, Applied Mechanics*, Master's Thesis 2012:1.
- [5] Jinming Liu and Huei Peng, "Modelling and Control of a Power-Split Hybrid Vehicle," *IEEE Transaction of Control Systems Technology*, November 2008, Vol.16.
- [6] John M.Miller, "Comparative Assessment of Hybrid Vehicle Power Split Transmissions," *4th VI Winter Workshop Series*, January 2005.
- [7] Benjamin Gressler and Breame Melius, "Regenerative Braking In Hybrid Electric Vehicles," Report, *University of Pittsburg, Swanson School of Engineering*, April 2013.
- [8] Martin Strehler, Soren Merting and Christian Schwan, "Energy-efficient shortest routes for electric and hybrid vehicles", *Transportation Research Part B: Methodological*, September 2017, pp. 111-135.

- [9] Hanna L. Breetz and Deborah Salon, “Do electric vehicles need subsidies? Ownership costs for conventional, hybrid and electric vehicles in 14 U.S. cities”, *Energy Policy*, September 2018, pp. 238-249.
- [10] Kazuyuki Iwata and Shigeru Matsumoto, “Use of hybrid vehicles in Japan: An analysis of used car market data”, *Transportation Research Part D: Transport and Environment*, July 2016, pp. 200-206.
- [11] Hassan Fathabadi, “Novel battery/Photovoltaic hybrid power source for plug-in hybrid electric vehicles”, *Jr. of Solar Energy*, January 2018, pp. 243-250.
- [12] Bradley W. Lane, Jerome Dumortier, et.al, “All plug-in electric vehicles are not same: Predictors of preference for a plug-in hybrid versus a battery-electric vehicle”, *Transportation Research Part D: Transport and Environment*, December 2018, pp. 1-13.
- [13] F. Millo, C. Cubito, et.al, “ Design and development of an hybrid light commercial vehicle”, *Jr. of Energy*, October 2017, pp. 90-99.
- [14] Anand R. Gopal, Won Young Park, et.al, “Hybrid and battery-electric vehicles offer low-cost climate benefits of China”, *Transportation Research Part D: Transportation and Environment*, July 2018, pp. 362-371.
- [15] Kate Palmer, James E. Tate, et.al, “Total cost of ownership and market share for hybrid and electric vehicle in the UK, US and Japan”, *Jr. of Applied Energy*, January 2018, pp. 108-119.